

SAFETY MANUAL

5 A SIL 3 NO contact Relay Output Module for NE or F&G/ND Load, DIN-Rail and Termination Board, Model D5094S

Reference must be made to the relevant sections within the instruction manual ISM0299,
which contain basic guides for the installation of the equipment.



1) Application for D5094S - SIL 3 for NE Load with bipolar load interruption

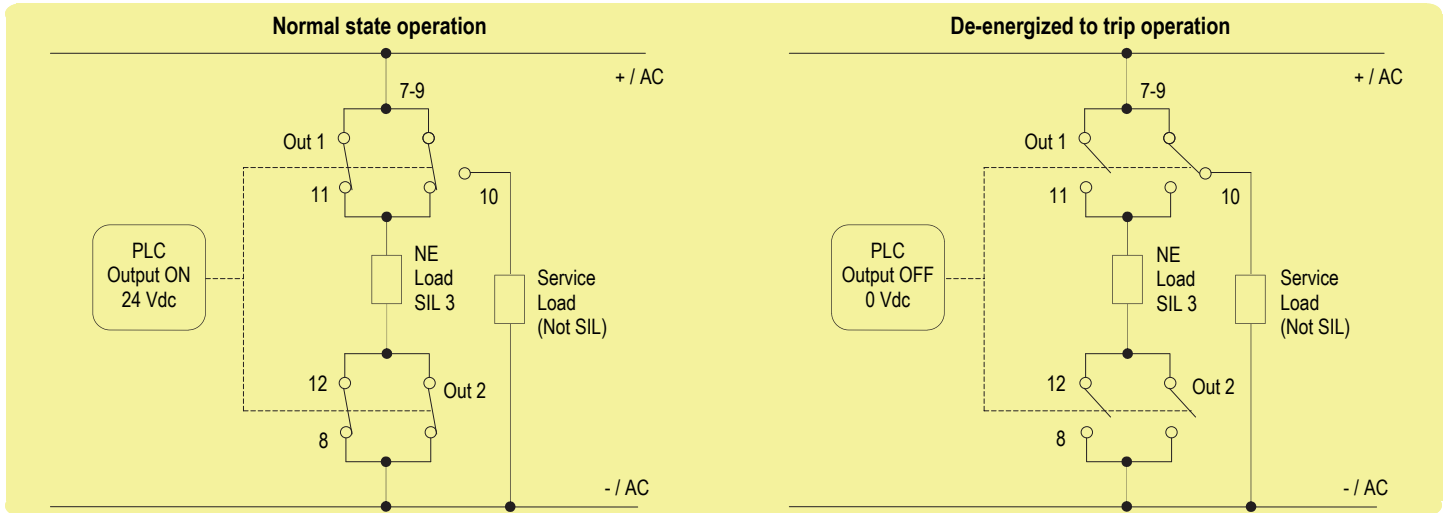

Description:

Input Signal from PLC/DCS is normally High (24 Vdc) and is applied to pins 1-2 in order to Normally Energize (NE) the internal relays. Input Signal from PLC/DCS is Low (0 Vdc) during “de-energized to trip” operation, in order to de-energize the internal relays. The Load is Normally Energized (NE), therefore its safe state is to be de-energized. The Service load (for NE Load) is normally de-energized, while in safe state it is energized. Disconnection of the NE Load is done on both supply lines. The following table describes the status (open or closed) of each output contact when the input signal is High or Low.

Operation	Input Signal Pins 1-2	Out 1 Pins 7 - 11	Out 2 Pins 8 - 12	NE Load (SIL3) Pins 11 - 12	Pins 9 - 10	Service Load (Not SIL) Pin 10 to -/AC
Normal	High (24 Vdc)	Closed	Closed	Energized	Open	De-Energized
Trip	Low (0 Vdc)	Open	Open	De-Energized	Closed	Energized

Safety Function and Failure behavior:

D5094S is considered a Type A module, having Hardware Fault Tolerance (HFT) = 0. In the 1st Functional Safety application, the normal state operation of relay module is energized, with NE (Normally Energized) load. In case of alarm or request from process, the relay module is de-energized (safe state), de-energizing the load. The failure behaviour of the relay module is described by the following definitions:

- fail-Safe State: it is defined as the output load being de-energized;
- fail Safe: this failure causes the system to go to the defined fail-safe state without a process demand;
- fail Dangerous: failure mode that does not respond to a demand from the process (i.e. being unable to go to the defined fail-safe state), so that the output load remains energized.
- fail “No effect”: failure mode of a component that plays a part in implementing the safety function but is neither a safe failure nor a dangerous failure; When calculating the SFF this failure mode is not taken into account.
- fail “Not part”: failure mode of a component which is not part of the safety function but part of the circuit diagram and is listed for completeness; When calculating the SFF this failure mode is not taken into account.

Failure rate date: taken from Siemens Standard SN29500.

Failure rate table:

Failure category	Failure rates (FIT)
λ_{dd} = Total Dangerous Detected failures	0.00
λ_{du} = Total Dangerous Undetected failures	1.60
λ_{sd} = Total Safe Detected failures	0.00
λ_{su} = Total Safe Undetected failures	253.24
$\lambda_{tot\ safe}$ = Total Failure Rate (Safety Function) = $\lambda_{dd} + \lambda_{du} + \lambda_{sd} + \lambda_{su}$	254.84
MTBF (safety function, single channel) = $(1 / \lambda_{tot\ safe}) + MTTR$ (8 hours)	447 years
$\lambda_{no\ effect}$ = “No effect” failures	196.76
$\lambda_{not\ part}$ = “Not Part” failures	20.60
$\lambda_{tot\ device}$ = Total Failure Rate (Device) = $\lambda_{tot\ safe} + \lambda_{no\ effect} + \lambda_{not\ part}$	472.20
MTBF (device) = $(1 / \lambda_{tot\ device}) + MTTR$ (8 hours)	241 years

Failure rates table according to IEC 61508:2010 Ed.2:

λ_{sd}	λ_{su}	λ_{dd}	λ_{du}	SFF
0.00 FIT	253.24 FIT	0.00 FIT	1.60 FIT	99.37%

When D5094S drives NE Load and operates in Low Demand mode:

PFDavg vs T[Proof] table (assuming Proof Test coverage of 99%), with determination of SIL supposing module contributes ≤ 10% of total SIF dangerous failures:

T[Proof] = 1 year	T[Proof] = 14 years
PFDavg = 7.02 E-06 - Valid for SIL 3	PFDavg = 9.83 E-05 - Valid for SIL 3

PFDavg vs T[Proof] table (assuming Proof Test coverage of 99%), with determination of SIL supposing module contributes > 10% of total SIF dangerous failures:

T[Proof] = 20 years
PFDavg = 1.40 E-04 - Valid for SIL 3

When D5094S drives NE Load and operates in High Demand mode: PFH = λ_{du} = 1.60 E-09 h⁻¹ - Valid for SIL 3.

SC 3: Systematic capability SIL 3.

2) Application for D5094S - SIL 3 for F&G/ND Load with bipolar load interruption

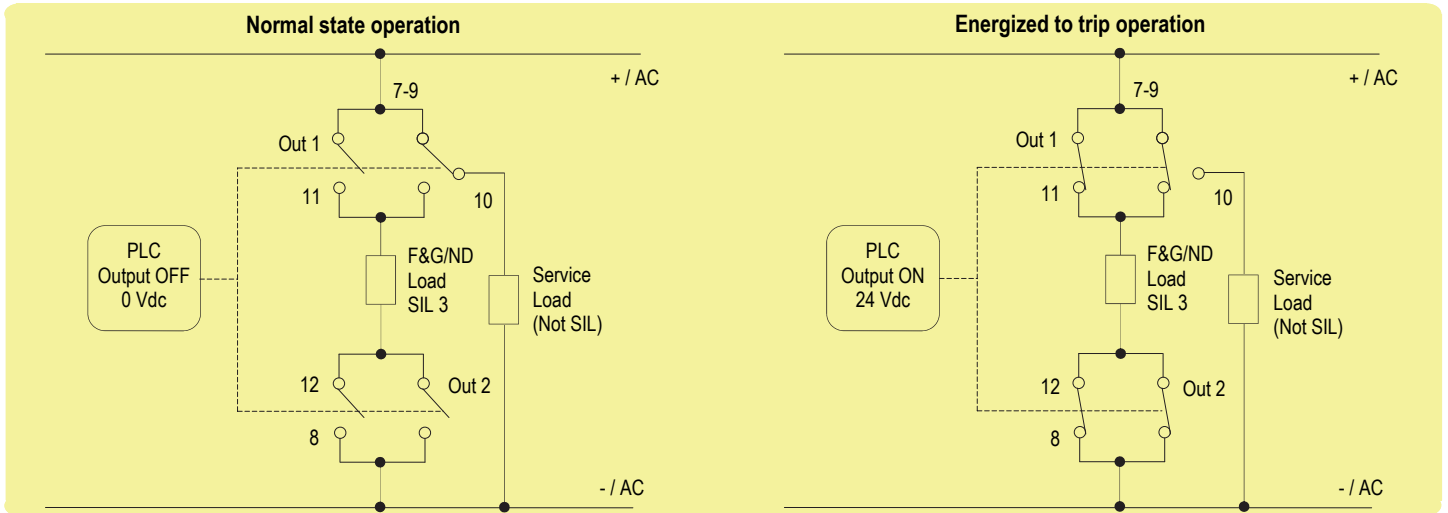

Description:

Input Signal from PLC/DCS is normally Low (0 Vdc) and is applied to pins 1-2 in order to Normally De-energize (ND) the internal relays. Input Signal from PLC/DCS is High (24 Vdc) during "energized to trip" operation, in order to energize the internal relays. The Load is Normally De-energized (ND), therefore its safe state is to be energized. The Service load (for ND Load) is normally energized, while in safe state it is de-energized. Disconnection of the ND Load is done on both supply lines. The following table describes the status (open or closed) of each output contact when the input signal is High or Low.

Operation	Input Signal Pins 1-2	Out 1 Pins 7 - 11	Out 2 Pins 8 - 12	F&G/ND Load (SIL3) Pins 11 - 12	Pins 9 - 10	Service Load (Not SIL) Pin 10 to -/AC
Normal	Low (0 Vdc)	Open	Open	De-energized	Closed	Energized
Trip	High (24 Vdc)	Closed	Closed	Energized	Open	De-energized

Safety Function and Failure behavior:

D5094S is considered a Type A module, having Hardware Fault Tolerance (HFT) = 0. In the 2nd Functional Safety application, the normal state operation of relay module is de-energized, with ND (Normally De-energized) load. In case of alarm or request from process, the relay module is energized (safe state), energizing the load. The failure behaviour of the relay module is described by the following definitions:

- fail-Safe State: it is defined as the output load being energized;
- fail Safe: this failure causes the system to go to the defined fail-safe state without a process demand;
- fail Dangerous: failure mode that does not respond to a demand from the process (i.e. being unable to go to the defined fail-safe state), so that the output load remains de-energized.
- fail "No effect": failure mode of a component that plays a part in implementing the safety function but is neither a safe failure nor a dangerous failure; When calculating the SFF this failure mode is not taken into account.
- fail "Not part": failure mode of a component which is not part of the safety function but part of the circuit diagram and is listed for completeness; When calculating the SFF this failure mode is not taken into account.

Failure rate date: taken from Siemens Standard SN29500.

Failure rate table:

Failure category	Failure rates (FIT)
λ_{dd} = Total Dangerous Detected failures	0.00
λ_{du} = Total Dangerous Undetected failures	3.46
λ_{sd} = Total Safe Detected failures	0.00
λ_{su} = Total Safe Undetected failures	133.80
$\lambda_{tot\ safe}$ = Total Failure Rate (Safety Function) = $\lambda_{dd} + \lambda_{du} + \lambda_{sd} + \lambda_{su}$	137.26
MTBF (safety function, single channel) = $(1 / \lambda_{tot\ safe}) + MTTR$ (8 hours)	831 years
$\lambda_{no\ effect}$ = "No effect" failures	314.74
$\lambda_{not\ part}$ = "Not Part" failures	20.20
$\lambda_{tot\ device}$ = Total Failure Rate (Device) = $\lambda_{tot\ safe} + \lambda_{no\ effect} + \lambda_{not\ part}$	472.20
MTBF (device) = $(1 / \lambda_{tot\ device}) + MTTR$ (8 hours)	241 years

Failure rates table according to IEC 61508:2010 Ed.2:

λ_{sd}	λ_{su}	λ_{dd}	λ_{du}	SFF
0.00 FIT	133.80 FIT	0.00 FIT	3.46 FIT	97.48%

When D5094S drives F&G/ND Load and operates in Low Demand mode:

PFDavg vs T[Proof] table (assuming Proof Test coverage of 99%), with determination of SIL supposing module contributes ≤ 10% of total SIF dangerous failures:

T[Proof] = 1 year	T[Proof] = 6 years
PFDavg = 1.52 E-05 - Valid for SIL 3	PFDavg = 9.11 E-05 - Valid for SIL 3

PFDavg vs T[Proof] table (assuming Proof Test coverage of 99%), with determination of SIL supposing module contributes > 10% of total SIF dangerous failures:

T[Proof] = 20 years
PFDavg = 3.04 E-04 - Valid for SIL 3

When D5094S drives F&G/ND Load and operates in High Demand mode: PFH = λ_{du} = 3.45 E-09 h⁻¹ - Valid for SIL 3.

SC 3: Systematic capability SIL 3.

3) Application for D5094S - SIL 3 for NE Load with unipolar load interruption

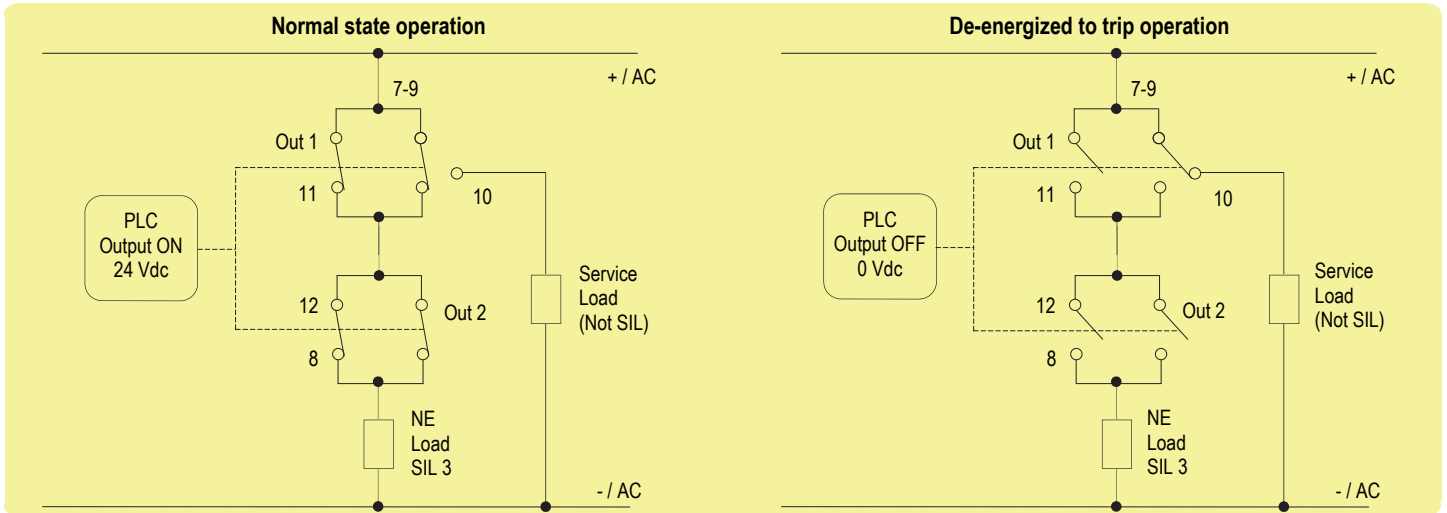

Description:

Input Signal from PLC/DCS is normally High (24 Vdc) and is applied to pins 1-2 in order to Normally Energize (NE) the internal relays. Input Signal from PLC/DCS is Low (0 Vdc) during “de-energized to trip” operation, in order to de-energize the internal relays. The Load is Normally Energized (NE), therefore its safe state is to be de-energized. The Service load (for NE Load) is normally de-energized, while in safe state it is energized. Disconnection of the NE Load is done on only one supply line. The following table describes the status (open or closed) of each output contact when the input signal is High or Low.

Operation	Input Signal Pins 1-2	Out 1 Pins 7 - 11	Out 2 Pins 8 - 12	NE Load (SIL3) Pin 8 to -/AC	Pins 9 - 10	Service Load (Not SIL) Pin 10 to -/AC
Normal	High (24 Vdc)	Closed	Closed	Energized	Open	De-Energized
Trip	Low (0 Vdc)	Open	Open	De-Energized	Closed	Energized

Safety Function and Failure behavior:

D5094S is considered a Type A module, having Hardware Fault Tolerance (HFT) = 0. In the 3rd Functional Safety application, the normal state operation of relay module is energized, with NE (Normally Energized) load. In case of alarm or request from process, the relay module is de-energized (safe state), de-energizing the load. The failure behaviour of the relay module is described by the following definitions:

- fail-Safe State: it is defined as the output load being de-energized;
- fail Safe: this failure causes the system to go to the defined fail-safe state without a process demand;
- fail Dangerous: failure mode that does not respond to a demand from the process (i.e. being unable to go to the defined fail-safe state), so that the output load remains energized.
- fail “No effect”: failure mode of a component that plays a part in implementing the safety function but is neither a safe failure nor a dangerous failure; When calculating the SFF this failure mode is not taken into account.
- fail “Not part”: failure mode of a component which is not part of the safety function but part of the circuit diagram and is listed for completeness; When calculating the SFF this failure mode is not taken into account.

Failure rate date: taken from Siemens Standard SN29500.

Failure rate table:

Failure category	Failure rates (FIT)
λ_{dd} = Total Dangerous Detected failures	0.00
λ_{du} = Total Dangerous Undetected failures	1.60
λ_{sd} = Total Safe Detected failures	0.00
λ_{su} = Total Safe Undetected failures	253.24
$\lambda_{tot\ safe}$ = Total Failure Rate (Safety Function) = $\lambda_{dd} + \lambda_{du} + \lambda_{sd} + \lambda_{su}$	254.84
MTBF (safety function, single channel) = $(1 / \lambda_{tot\ safe}) + MTTR$ (8 hours)	447 years
$\lambda_{no\ effect}$ = “No effect” failures	196.76
$\lambda_{not\ part}$ = “Not Part” failures	20.60
$\lambda_{tot\ device}$ = Total Failure Rate (Device) = $\lambda_{tot\ safe} + \lambda_{no\ effect} + \lambda_{not\ part}$	472.20
MTBF (device) = $(1 / \lambda_{tot\ device}) + MTTR$ (8 hours)	241 years

Failure rates table according to IEC 61508:2010 Ed.2:

λ_{sd}	λ_{su}	λ_{dd}	λ_{du}	SFF
0.00 FIT	253.24 FIT	0.00 FIT	1.60 FIT	99.37%

When D5094S drives NE Load and operates in Low Demand mode:

PFDavg vs T[Proof] table (assuming Proof Test coverage of 99%), with determination of SIL supposing module contributes ≤ 10% of total SIF dangerous failures:

T[Proof] = 1 year	T[Proof] = 14 years
PFDavg = 7.02 E-06 - Valid for SIL 3	PFDavg = 9.83 E-05 - Valid for SIL 3

PFDavg vs T[Proof] table (assuming Proof Test coverage of 99%), with determination of SIL supposing module contributes > 10% of total SIF dangerous failures:

T[Proof] = 20 years
PFDavg = 1.40 E-04 - Valid for SIL 3

When D5094S drives NE Load and operates in High Demand mode: PFH = λ_{du} = 1.60 E-09 h⁻¹ - Valid for SIL 3.

SC 3: Systematic capability SIL 3.

4) Application for D5094S - SIL 3 for F&G/ND Load with unipolar load interruption

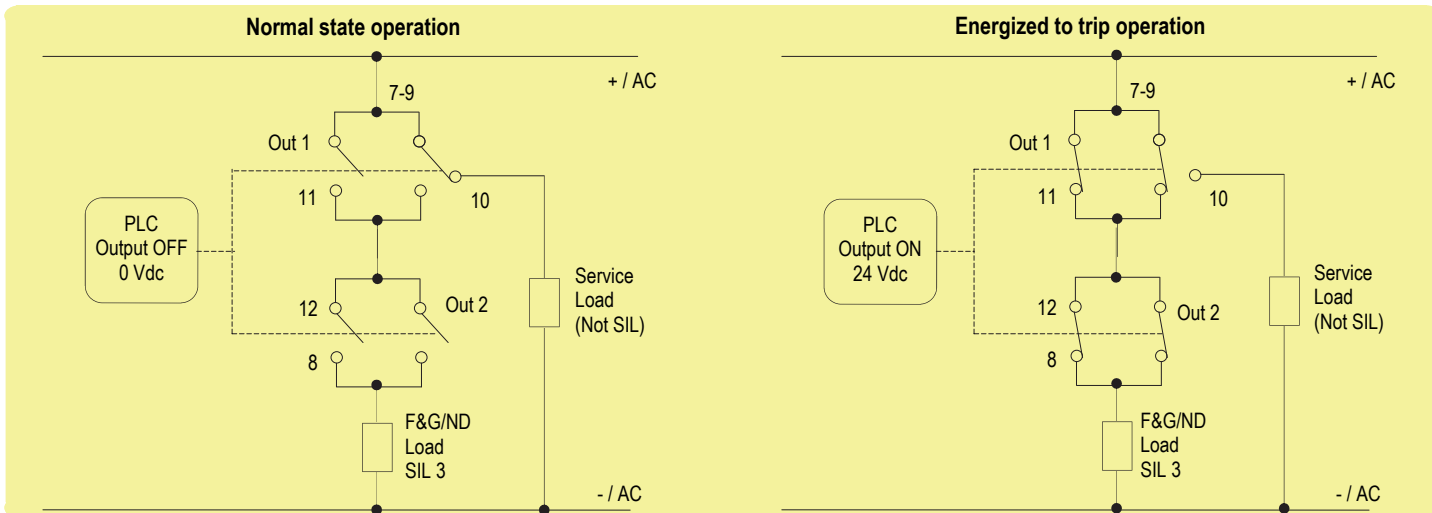

Description:

Input Signal from PLC/DCS is normally Low (0 Vdc) and is applied to pins 1-2 in order to Normally De-energize (ND) the internal relays. Input Signal from PLC/DCS is High (24 Vdc) during "energized to trip" operation, in order to energize the internal relays. The Load is Normally De-energized (ND), therefore its safe state is to be energized. The Service load (for ND Load) is normally energized, while in safe state it is de-energized. Disconnection of the ND Load is done on only one supply line. The following table describes the status (open or closed) of each output contact when the input signal is High or Low.

Operation	Input Signal Pins 1-2	Out 1 Pins 7 - 11	Out 2 Pins 8 - 12	F&G/ND Load (SIL3) Pin 8 to -/AC	Pins 9 - 10	Service Load (Not SIL) Pin 10 to -/AC
Normal	Low (0 Vdc)	Open	Open	De-energized	Closed	Energized
Trip	High (24 Vdc)	Closed	Closed	Energized	Open	De-energized

Safety Function and Failure behavior:

D5094S is considered a Type A module, having Hardware Fault Tolerance (HFT) = 0. In the 4th Functional Safety application, the normal state operation of relay module is de-energized, with ND (Normally De-energized) load. In case of alarm or request from process, the relay module is energized (safe state), energizing the load.

The failure behaviour of the relay module is described by the following definitions:

- fail-Safe State: it is defined as the output load being energized;
- fail Safe: this failure causes the system to go to the defined fail-safe state without a process demand;
- fail Dangerous: failure mode that does not respond to a demand from the process (i.e. being unable to go to the defined fail-safe state), so that the output load remains de-energized.
- fail "No effect": failure mode of a component that plays a part in implementing the safety function but is neither a safe failure nor a dangerous failure; When calculating the SFF this failure mode is not taken into account.
- fail "Not part": failure mode of a component which is not part of the safety function but part of the circuit diagram and is listed for completeness; When calculating the SFF this failure mode is not taken into account.

Failure rate data: taken from Siemens Standard SN29500.

Failure rate table:

Failure category	Failure rates (FIT)
λ_{dd} = Total Dangerous Detected failures	0.00
λ_{du} = Total Dangerous Undetected failures	3.46
λ_{sd} = Total Safe Detected failures	0.00
λ_{su} = Total Safe Undetected failures	133.80
$\lambda_{tot\ safe}$ = Total Failure Rate (Safety Function) = $\lambda_{dd} + \lambda_{du} + \lambda_{sd} + \lambda_{su}$	137.26
MTBF (safety function, single channel) = $(1 / \lambda_{tot\ safe}) + MTTR$ (8 hours)	831 years
$\lambda_{no\ effect}$ = "No effect" failures	314.74
$\lambda_{not\ part}$ = "Not Part" failures	20.20
$\lambda_{tot\ device}$ = Total Failure Rate (Device) = $\lambda_{tot\ safe} + \lambda_{no\ effect} + \lambda_{not\ part}$	472.20
MTBF (device) = $(1 / \lambda_{tot\ device}) + MTTR$ (8 hours)	241 years

Failure rates table according to IEC 61508:2010 Ed.2:

λ_{sd}	λ_{su}	λ_{dd}	λ_{du}	SFF
0.00 FIT	133.80 FIT	0.00 FIT	3.46 FIT	97.48%

When D5094S drives F&G/ND Load and operates in Low Demand mode:

PFDavg vs T[Proof] table (assuming Proof Test coverage of 99%), with determination of SIL supposing module contributes ≤ 10% of total SIF dangerous failures:

T[Proof] = 1 year	T[Proof] = 6 years
PFDavg = 1.52 E-05 - Valid for SIL 3	PFDavg = 9.11 E-05 - Valid for SIL 3

PFDavg vs T[Proof] table (assuming Proof Test coverage of 99%), with determination of SIL supposing module contributes > 10% of total SIF dangerous failures:

T[Proof] = 20 years
PFDavg = 3.04 E-04 - Valid for SIL 3

When D5094S drives F&G/ND Load and operates in High Demand mode: PFH = λ_{du} = 3.46 E-09 h⁻¹ - Valid for SIL 3.

SC 3: Systematic capability SIL 3.

Testing procedure at T-proof

The proof test shall be performed to reveal dangerous faults which are undetected by diagnostic. This means that it is necessary to specify how dangerous undetected faults, which have been noted during the FMEDA, can be revealed during proof test.

Before of Specific Proof Test, execute the following **General Proof Test**: connect the load supply lines to terminal blocks "7" (for +/AC) and "8" (for -/AC) and the NE of F&G / ND load to terminal blocks "11" (as the positive terminal) and "12" (as the negative terminal); finally, connect the DCS/PLC signal to input channel terminal blocks "1" (as the positive terminal) and "2" (as the negative terminal). Then, verify the input to output functionality: the output NE load is normally energized by supplying the input channel, while shutdown of the input channel de-energizes (safe state) the load; on the other hand, the output F&G / ND load is normally de-energized by shutdown of the input channel, while supplying the input channel energizes (safe state) the load. The channel functionality must be verified for a minimum to maximum input voltage change (from 21.6 to 27.6 Vdc).

Then, disconnect the load supply lines from terminal blocks "7" - "8" and the output load from terminal blocks "11" - "12". Then, connect an ohmmeter (Ohm. A) between terminal blocks "7" - "11" and another one (Ohm. B) between terminal blocks "8" - "12". In addition, the use of four relays for a single channel requires to control each relay coil by means of the internal SW1 dip-switches (no. 1, 2, 3, 4) and to check the ohmic continuity of the contacts, as described in the following Specific Proof Test.

The **Specific Proof Test** consists of the following steps:

Steps	Action
1	Bypass the safety-related PLC or take any other appropriate action to avoid a false trip when removing the unit for test.
2	<ol style="list-style-type: none"> 1. Do not supply the input channel (terminals "1" - "2") of the unit under test and verify that ohmmeters Ohm. A and Ohm. B measure absence of ohmic continuity (so that both +/AC and -/AC load lines are interrupted because all NO contacts are open: the 1st requisite is verified). For both ohmmeters, Ohm. A or Ohm. B, these measures could also be true if only one of the two relay contacts in parallel is open and the other one is blocked (for welding) in the open position: this can be verified by testing the channel when the input is supplied, as described in point 3 of this procedure. On the other hand, the presence of ohmic continuity measured by ohmmeters Ohm. A or Ohm. B, implies that at least one relay contact is blocked (for welding) in the closed position: this can be verified only by disassembling and individually testing each relay. 2. Supply the input channel (terminals "1" - "2") of the unit under test and verify that ohmmeters Ohm. A and Ohm. B measure presence of ohmic continuity (so that both +/AC and -/AC load lines are not interrupted because the NO contacts are closed: the 2nd requisite is verified). The absence of ohmic continuity measured by ohmmeter Ohm. A or Ohm. B implies that the two relay contacts are blocked (for welding) in the open position. 3. Always supply the input channel (terminals "1" - "2") of the unit under test in order to verify if a single contact is blocked (for welding) in the open position. Considering the measure of ohmmeter Ohm. A, set ON the internal SW1 dip-switches (no. 1 or 2) to put in short circuit one relay coil at a time (starting with the 1st coil by dip-switch no. 1, then going on with the 2nd coil by dip-switch no. 2), verifying that ohmic continuity is always present between terminals "7" - "11". Considering the measures of ohmmeter Ohm. B, set ON the internal SW1 dip-switches (no. 3 or 4) to put in short circuit one relay coil at a time (starting with the 3rd coil by dip-switch no. 3, then going on with the 4th coil by DIP-switch no. 4), verifying that ohmic continuity is always present between terminals "8" - "12". In these situations, the absence of ohmic continuity implies that a relay contact (the one with the energized coil because the other one is de-energized, being its dip-switch set ON) is blocked (for welding) in the open position.
3	Remove the bypass from the safety-related PLC or restore normal operation inserting the unit.

This test reveals almost 99 % of all possible Dangerous Undetected failures in the relay module.

Configuration

For configuration of T-proof relays testing, some DIP Switches are located on component side of pcb. These switches allow the T-proof relays test (SW1 dip-switch: 1-2-3-4 set "ON" and see "Testing procedure at T-proof" section for more information).

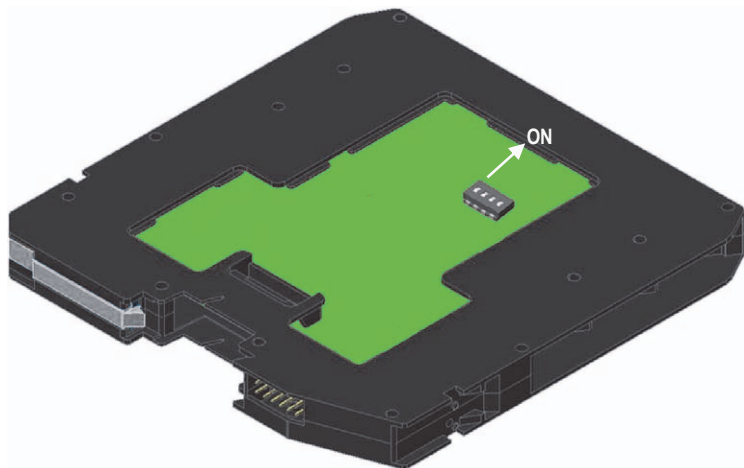

SW1 Dip switch configuration

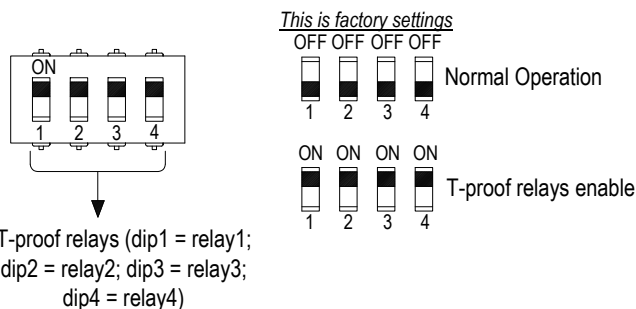

WARNING: after T-proof test, dip-switch 1-2-3-4 must be set to "OFF" position for normal operation.