

TBE-D5016-TRI-001

SIL3 16-pos Term. Board for Tricon AI cards 3704E and 3720

This Termination Board with Enclosure (TBE) provides direct connection between the I/O Card of the system and D5000 / D6000 Series modules. The Intrinsically Safe protection and signal isolation between Safe and Hazardous Area, is provided by D5000 Series Associated Apparatus. The 24 Vdc Power Supply of the TBE is connected to two plug-in terminal blocks, for a redundant power supply.

FEATURES

- SIL 3 / SC 3
- Zone 2/Div. 2 Installation
- Tricon AI Cards board interfaces
- Connection to external GMI HART Mux 5700
- 16 positions Termination Board for up to 32 channels
- Lower cables installation and maintenance costs
- Power supplies fault monitoring
- Mounting hardware provided for single DIN Rail mounting kit

SYSTEM	I/O CARD	CARDS / BOARDS	MODULES
Tricon	3704E 3720	1/2	D5011D, D5014D, D5072D, D6001D, D6011D, D6014D, D6072D

TERMINATION BOARD IMAGE

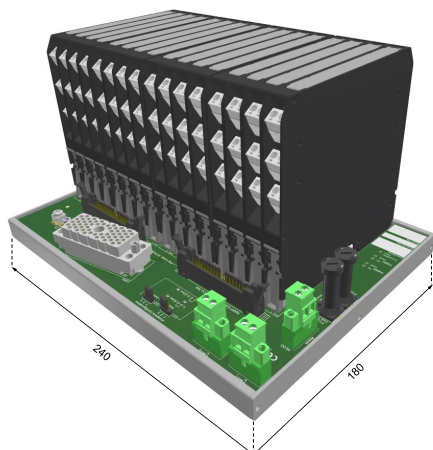

TECHNICAL DATA

General

Number of positions: 16

Maximum number of channels: 32

Supply

24 Vdc nom (20 to 30 Vdc), reverse polarity protected, double terminal blocks for redundant power supply, with OR diodes to mix supply voltages.

Max allowed current consumption: 1.5 A (as total supply).

Connection: by polarized plug-in disconnect screw terminal blocks to accommodate terminations up to 2.5 mm².

Protection fuse: 4 A time lag.

Fault detection

The on-board diagnostic monitors both power supplies integrity and the module cumulative fault. Any malfunction is reported by deactivating a solid-state relay and activating the corresponding LEDs.

Alarm is issued if:

- 1) Power supply 1 or 2 < 17 Vdc or
- 2) Power supply 1 or 2 > 33 Vdc or
- 3) Module cumulative fault ON.

Alarm is removed if:

- 1) 20 Vdc < Power supply 1 and 2 < 30 Vdc and
- 2) No module cumulative fault.

Connection: by polarized plug-in disconnect screw terminal blocks to accommodate terminations up to 2.5 mm².

Output rating: 100 mA 35 V (≤ 1 V voltage drop).

I/O Card Interface

Connection: 1 x ELCO 8016, 56-poles receptacle connector (require male mating connector).

Connector Keys: CON1, Large Key pos.5, Small Key pos.1

Cable: system cable 4000206-5xx.

HART Mux Interface

Connection: 2 x 34-poles receptacle connector (require female mating connector).

Cable: flat cable CABF032.

Environmental conditions

Operating temperature: temperature limits -40 to +70 °C.

Max altitude: 2000 m a.s.l.

Storage temperature: temperature limits -45 to +80 °C.

Mounting

Hardware included for mounting on single DIN-rail 35 mm.

Weight: about 1 kg, excluding modules (+ 50 g plastic clips or 380 g metal clips).

Location: installation in Safe Area or Zone 2, Group IIC T4, or Class 1, Div. 2, Group A, B, C, D, T4.

Dimensions: Width 240 mm, Depth 180 mm, Height 154 mm.

ORDERING INFORMATION

Ordering codes

TBE-D5016-TRI-001

Accessories

The Termination Board is already provided with plastic DIN-rail clips. Metal clips, replacement plastic clips as well as conformal coating must be ordered as a separate accessory according to the following items.

TBE-FIX-PL-001(x2) Plastic DIN-rail clips

TBE-FIX-MT-001(x2) Metal DIN-rail clips

TBE-MNT-001(x2) Factory assembly of TBE-FIX-MT-001

TBE-CTG-002 Conformal coating

FUNCTION DIAGRAM

Additional installation diagrams may be found in Instruction Manual.

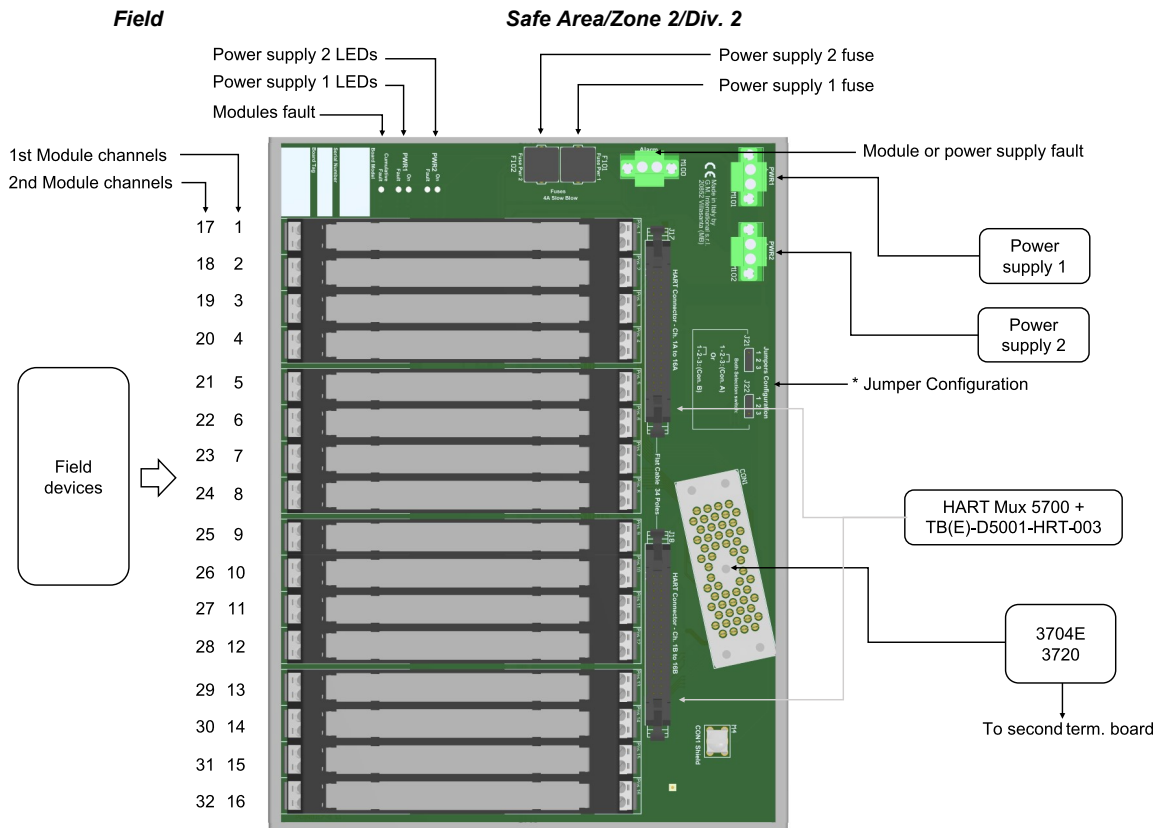

*Jumper Configuration

To cover all 64 channels provided with 3704E / 3720 cards, two termination boards are required with the following jumper configuration:

	3704E 3720
TB n.1	J21 2-3 J22 2-3
TB n.2	J21 1-2 J22 1-2