

# INSTRUCTION MANUAL

SIL2 Switch/Proximity Relay-Out Repeater  
DIN-Rail,  
Model D5232Q



## Characteristics

### General Description:

The Switch/Proximity Detector Repeater D5232 is a module suitable for applications requiring SIL 2 level in safety related systems for high risk industries. The unit can be configured for switches or proximity detectors, located in Hazardous Area, and repeats the input state to a relay contact in Safe Area. The selectable fault detection circuit is available for proximity sensors or switches equipped with end-of-line resistors. Input-to-output function can be inverted, and signals can be duplicated.

Mounting on standard DIN-Rail, with or without Power Bus, in Safe Area / Non Hazardous Location or in Zone 2 / Class I, Division 2 or Class I, Zone 2.

## Technical Data

### Supply:

24 Vdc nom (18 to 30 Vdc), reverse polarity protected.

**Current consumption:** 75 mA @ 24 Vdc with short circuit input and output closed, typical.

**Power dissipation:** 1.8 W @ 24 Vdc with short circuit input and output closed, typical, excluding output contact dissipation.

### Isolation:

I.S. In/Out 2.5 kV; I.S. In/Supply 2.5 kV; Out/Supply 500 V; Out/Out 500 V.

### Input:

Voltage source according to NAMUR standard.

**Input equivalent source:** 7.5 V/1 k $\Omega$  typical (7.5 V no load, 7.5 mA short).

**Input switching current levels:** ON  $\geq$  2.1 mA, OFF  $\leq$  1.2 mA.

**No fault:** input current  $\geq$  0.35 mA and input resistance  $\geq$  360  $\Omega$ .

**Open fault:** input current  $\leq$  0.05 mA.

**Short fault:** input resistance  $\leq$  100  $\Omega$ .

### Output:

Voltage free SPST relay contact.

**Contact material:** AgNi90/10.

**Contact rating:** 2 A 250 Vac 500 VA, 2 A 250 Vdc 80 W (resistive load).

**Mechanical / electrical life:**  $15 \times 10^6 / 10 \times 10^4$  operation, typical.

**Input-output delay:** 20 ms, maximum.

**Frequency response:** 10 Hz, maximum.

**Output typical characteristics:**

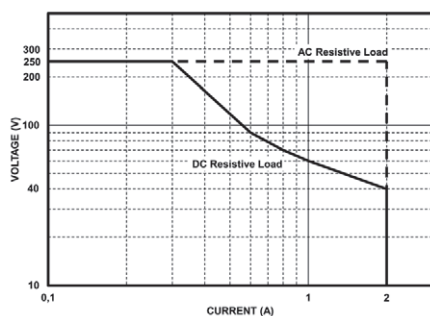

### Compatibility:



CE mark compliant, conforms to Directive: 2014/34/EU ATEX, 2014/30/EU EMC, 2014/35/EU LVD, 2011/65/EU RoHS.

### Environmental conditions:

**Operating:** temperature limits - 40 to + 70 °C, relative humidity 95 %, up to 55 °C.

**Storage:** temperature limits - 45 to + 80 °C.

**Max altitude:** 2000 m a.s.l.

### Safety Description:



**ATEX:** II 3(1)G Ex ec nC [ia Ga] IIC T4 Gc, II (1)D [Ex ia Da] IIIC, I (M1) [Ex ia Ma] I.

**IECEX:** Ex ec nC [ia Ga] IIC T4 Gc, [Ex ia Da] IIIC, [Ex ia Ma] I.

**UL:** NI / I / 2 / ABCD / T4, AIS / I, II, III / 1 / ABCDEFG, AEx ec nC [ia Ga] IIC T4 Gc; **C-UL:** NI / I / 2 / ABCD / T4, AIS / I, II, III / 1 / ABCDEFG, Ex ec nC [ia Ga] IIC T4 Gc X. associated apparatus and non-sparking electrical equipment.

Uo/Voc = 11.2 V, Io/Isc = 12 mA, Po/Po = 34 mW at terminals 13-14, 15-16, 17-18, 19-20.

Um = 250 Vrms, -40 °C  $\leq$  Ta  $\leq$  70 °C.

### Approvals:

UL 24 ATEX 3258X conforms to EN60079-0, EN60079-7, EN60079-11, EN60079-15.

IECEX ULD 24.0021 X conforms to IEC60079-0, IEC60079-7, IEC60079-11, IEC60079-15.

UL & C-UL E222308 conforms to UL61010-1, UL913, UL 121201, UL 60079-0, UL60079-11, UL60079-7, UL60079-15 for UL

and CAN/CSA C22.2 No. 61010-1-12, CSA C22.2 No. 213, CAN/CSA C22.2 No. 60079-0, CAN/CSA C22.2 No. 60079-11, CAN/CSA No. 60079-7, CAN/CSA No. 60079-15 for C-UL.

SIL 2 conforms to IEC61508:2010 Ed.2.

### Mounting:

EN/IEC60715 TH 35 DIN-Rail with or without Power Bus.

**Weight:** about 175 g.

**Connection:** by polarized plug-in disconnect screw terminal blocks to accommodate terminations up to 2.5 mm<sup>2</sup> (13 AWG).

**Location:** installation in Safe Area/Non Hazardous Locations or Zone 2, Group IIC T4 or Class I, Division 2, Group A,B,C,D, T4 or Class I, Zone 2, Group IIC, T4.

**Protection class:** IP 20.

**Dimensions:** Width 22.5 mm, Depth 123 mm, Height 120 mm.

## Programming

The module is fully programmable. Operating parameters can be changed from PC via PPC5092 adapter connected to USB serial line and SWC5090 software.

Measured values and diagnostic alarms can be read on serial configuration.

SWC5090 software also allows the Monitoring and Recording of values. For details please see SWC5090 manual ISM0154.

## Ordering Information

Model:	D5232	
4 channels		Q

Power Bus and DIN-Rail accessories:  
Connector JDFT050

Bus Mounting Kit OPT5096

## Front Panel and Features

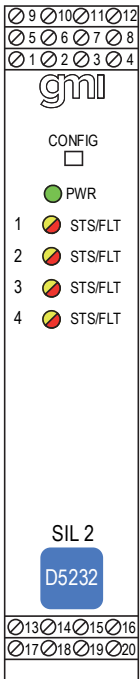

- SIL 2 / SC 3 (pending)
- Input from Zone 0/Div. 1
- Installation in Zone 2/Div. 2
- High output current
- Field open and short circuit detection
- Input inversion available
- Duplication available
- Three port isolation, Input/Output/Supply
- High Density, four channels per unit

## Terminal block connections

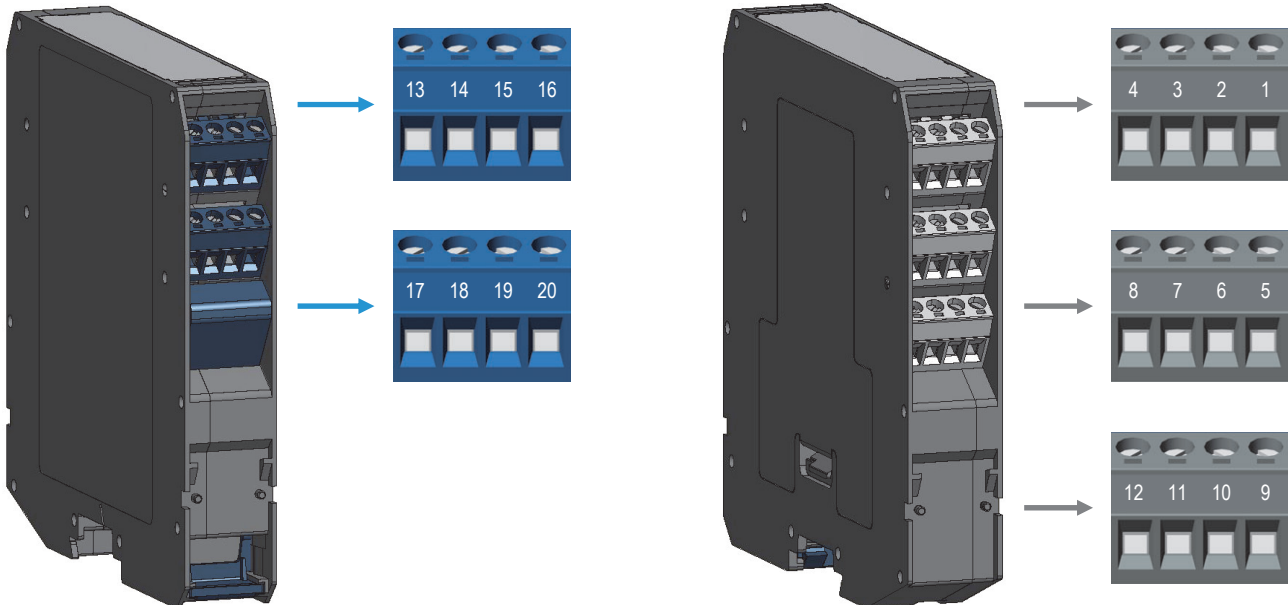

### HAZARDOUS AREA

13	+ Input Ch 1 for Proximity or Voltage free Contact
14	- Input Ch 1 for Proximity or Voltage free Contact
15	+ Input Ch 2 for Proximity or Voltage free Contact
16	- Input Ch 2 for Proximity or Voltage free Contact
17	+ Input Ch 3 for Proximity or Voltage free Contact
18	- Input Ch 3 for Proximity or Voltage free Contact
19	+ Input Ch 4 for Proximity or Voltage free Contact
20	- Input Ch 4 for Proximity or Voltage free Contact
21	-
22	-
23	-
24	-

### SAFE AREA

1	+ Output Ch 1
2	- Output Ch 1
3	+ Output Ch 2
4	- Output Ch 2
5	+ Output Ch 3
6	- Output Ch 3
7	+ Output Ch 4
8	- Output Ch 4
9	+ Power Supply 24 Vdc
10	- Power Supply 24 Vdc
11	-
12	-

## Parameters Table

In the system safety analysis, always check the Hazardous Area/Hazardous Locations devices to conform with the related system documentation, if the device is Intrinsically Safe check its suitability for the Hazardous Area/Hazardous Locations and group encountered and that its maximum allowable voltage, current, power ( $U_i/V_{max}$ ,  $I_i/I_{max}$ ,  $P_i/P_i$ ) are not exceeded by the safety parameters ( $U_o/V_{oc}$ ,  $I_o/I_{sc}$ ,  $P_o/P_o$ ) of the D5232 series Associated Apparatus connected to it. Also consider the maximum operating temperature of the field device, check that added connecting cable and field device capacitance and inductance do not exceed the limits ( $C_o/C_a$ ,  $L_o/L_a$ ,  $L_o/R_o$ ) given in the Associated Apparatus parameters for the effective group. See parameters indicated in the table below:

D5232 Terminals	D5232 Associated Apparatus Parameters	Must be	Hazardous Area/ Hazardous Locations Device Parameters
13-14, 15-16, 17-18, 19-20	$U_o / V_{oc} = 11.2 \text{ V}$	$\leq$	$U_i / V_{max}$
	$I_o / I_{sc} = 12 \text{ mA}$	$\leq$	$I_i / I_{max}$
	$P_o / P_o = 34 \text{ mW}$	$\leq$	$P_i / P_i$
D5232 Terminals	D5232 Associated Apparatus Parameters Cenelec (US)	Must be	Hazardous Area/ Hazardous Locations Device + Cable Parameters
13-14, 15-16, 17-18, 19-20	$C_o / C_a = 1.83 \mu\text{F}$	$\geq$	$C_i / C_i \text{ device} + C \text{ cable}$
	$C_o / C_a = 12.5 \mu\text{F}$		
	$C_o / C_a = 53.9 \mu\text{F}$		
	$C_o / C_a = 57.9 \mu\text{F}$		
	$C_o / C_a = 12.5 \mu\text{F}$		
	$L_o / L_a = 253.4 \text{ mH}$	$\geq$	$L_i / L_i \text{ device} + L \text{ cable}$
	$L_o / L_a = 1000 \text{ mH}$		
	$L_o / L_a = 1000 \text{ mH}$		
	$L_o / L_a = 1000 \text{ mH}$		
	$L_o / L_a = 1000 \text{ mH}$		
	$L_o / R_o = 1074 \mu\text{H}/\Omega$	$\geq$	$L_i / R_i \text{ device and}$ $L \text{ cable} / R \text{ cable}$
	$L_o / R_o = 4299 \mu\text{H}/\Omega$		
$L_o / R_o = 8599 \mu\text{H}/\Omega$			
$L_o / R_o = 14108 \mu\text{H}/\Omega$			
$L_o / R_o = 4299 \mu\text{H}/\Omega$			

For installations in which both the  $C_i$  and  $L_i$  of the Intrinsically Safe apparatus exceed 1% of the  $C_o$  and  $L_o$  parameters of the Associated Apparatus (excluding the cable), then 50% of  $C_o$  and  $L_o$  parameters are applicable and shall not be exceeded (50% of the  $C_o$  and  $L_o$  become the limits which must include the cable such that  $C_i \text{ device} + C \text{ cable} \leq 50\%$  of  $C_o$  and  $L_i \text{ device} + L \text{ cable} \leq 50\%$  of  $L_o$ ). The reduced capacitance of the external circuit (including cable) shall not be greater than 1  $\mu\text{F}$  for Groups I, IIA, IIB and 600 nF for Group IIC. If the cable parameters are unknown, the following value may be used: Capacitance 200 pF per meter (60 pF per foot), Inductance 1  $\mu\text{H}$  per meter (0.20  $\mu\text{H}$  per foot).

## Function Diagram

HAZARDOUS AREA ZONE 0 (ZONE 20) GROUP IIC,  
HAZARDOUS LOCATIONS CLASS I, DIVISION 1, GROUPS A, B, C, D,  
CLASS II, DIVISION 1, GROUPS E, F, G, CLASS III, DIVISION 1,  
CLASS I, ZONE 0, GROUP IIC

SAFE AREA, ZONE 2 GROUP IIC T4,  
NON HAZARDOUS LOCATIONS, CLASS I, DIVISION 2,  
GROUPS A, B, C, D T-Code T4, CLASS I, ZONE 2, GROUP IIC T4

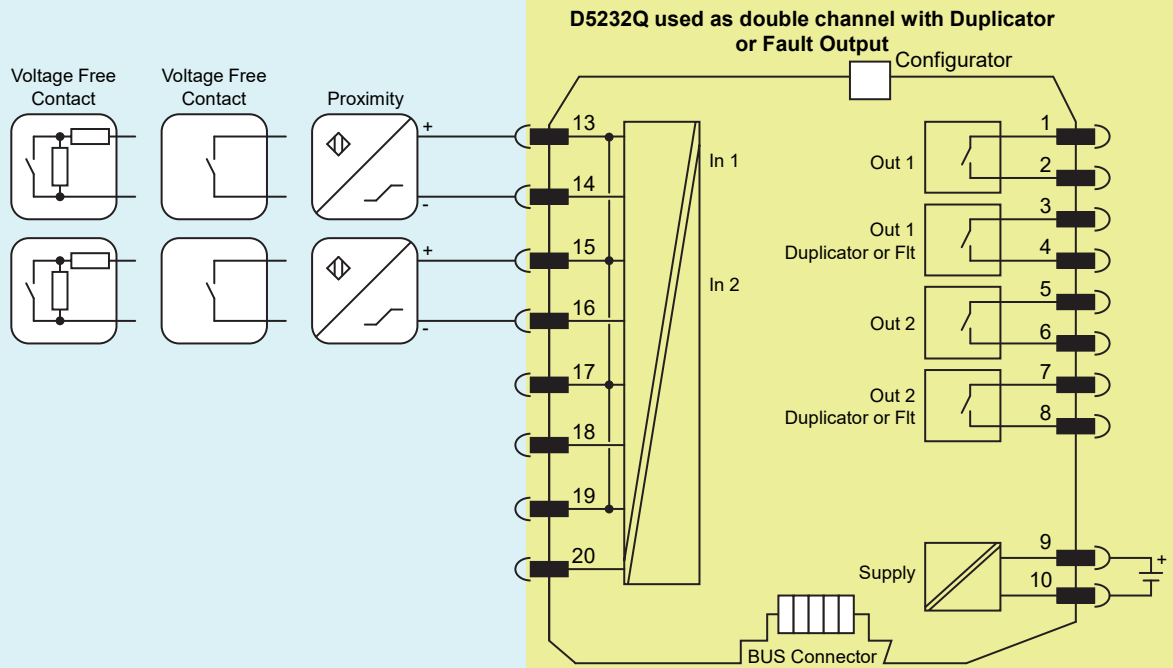
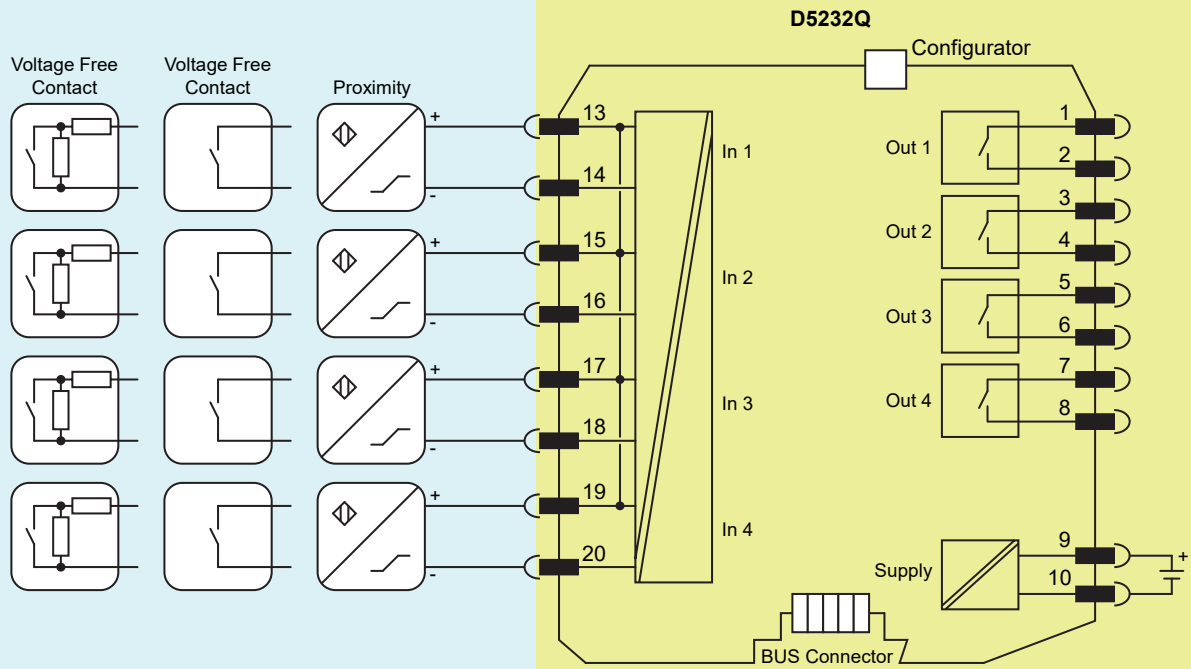

## Warning

D5232 series is an isolated Intrinsically Safe Associated Apparatus installed into standard EN/IEC60715 TH 35 DIN-Rail located in Safe Area or Zone 2, Group IIC, Temperature T4 or Class I, Division 2, Group A, B, C, D, T4 Hazardous Area within the specified operating temperature limits Tamb -40 to +70 °C, and connected to equipment with a maximum limit for power supply Um of 250 Vrms or Vdc. Not to be connected to control equipment that uses or generates more than 250 Vrms or Vdc with respect to earth ground.

D5232 series must be installed, operated and maintained only by qualified personnel, in accordance with the relevant national/international installation standards (e.g. IEC/EN60079-14 Electrical apparatus for explosive gas atmospheres - Part 14: Electrical installations in hazardous areas (other than mines)), following the established installation rules; particular care must be given to segregation and clear identification of I.S. conductors from non I.S. ones.

De-energize power source (turn off power supply voltage) before plug or unplug the terminal blocks when installed in Hazardous Area or unless area is known to be nonhazardous.

**Warning: substitution of components may impair Intrinsic Safety and suitability for Zone 2/Division 2. Avertissement: la substitution des composants peut nuire à la sécurité intrinsèque et à l'aptitude à la Zone 2/Div. 2.**

**Explosion Hazard: to prevent ignition of flammable atmospheres, disconnect power before servicing or unless area is known to be nonhazardous. Danger d'Explosion: pour éviter l'inflammation d'atmosphères inflammables, débrancher l'alimentation avant l'entretien ou à moins que région est connue pour être non dangereuse.**

**Warning: de-energize main power source (turn off power supply voltage) and disconnect plug-in terminal blocks before opening the enclosure to avoid electrical shock when connected to live hazardous potential. Avertissement: débrancher l'alimentation (couper la tension d'alimentation) et les blocs de jonction enfichables avant d'ouvrir le boîtier pour éviter les chocs électriques lorsqu'ils sont connectés à un potentiel dangereux.**

Failure to properly installation or use of the equipment may risk to damage the unit or severe personal injury. The unit cannot be repaired by the end user and must be returned to the manufacturer or his authorized representative. Any unauthorized modification must be avoided.

## Operation

The Switch/Proximity Detector Repeater type D5232Q is a unit with four independent channels suitable for applications requiring SIL 2 level (according to IEC 61508:2010) in safety related systems for high risk industries.

The unit can be configured for switch or proximity detector (EN60947-5-6 NAMUR), NO or NC input and for NO or NC output relay contact. Configuration is programmable from PC by the GM Pocket Portable Adapter PPC5092 via USB serial line and SWC5090 Configurator software. Each channel enables a Safe Area load to be controlled by a switch, or a proximity detector, located in Hazardous Area.

Fault detection circuit (configurable by PC) is available for all proximity sensors and switches equipped with end of line resistors. In case of fault, when enabled it de-energizes the corresponding relay and turns the fault red LED on; when disabled the corresponding relay contact repeats the input line open or closed status as configured.

**Note:** use of voltage free electrical contacts with fault detection enabled (control equipment) requires, near the switch at the end of the line a R1=1 K $\Omega$  typical (470  $\Omega$  to 2 K $\Omega$  range) resistor in series and a R2=10 k $\Omega$  typical (5 K $\Omega$  to 15 K $\Omega$  range) resistor in parallel to the contacts in order to allow the fault detection circuit to distinguish between a condition of contact close/open and a line open/short circuit fault.

## Installation

D5232 series module is housed in a plastic enclosure suitable for installation on EN/IEC60715 TH 35 DIN-Rail, with or without Power Bus.

D5232 series can be mounted with any orientation over the entire ambient temperature range.

Electrical connection are accommodated by polarized plug-in removable screw terminal blocks which can be plugged in/out into a powered unit without suffering or causing any damage **(for Zone 2 installations check the area to be nonhazardous before servicing)**. Connect only one individual conductor per each clamping point, use conductors from 0.2 mm<sup>2</sup> (24 AWG) up to 2.5 mm<sup>2</sup> (13 AWG) and a torque value of 0.5-0.6 Nm. For USA and Canada installations, use only cables that are suitable for a temperature of at least 75°C. The wiring cables have to be proportionate in base to the current and the length of the cable. USB connector is for configuration and maintenance purpose only, not for use in hazardous locations area.

On the section "Function Diagram" and enclosure side a block diagram identifies all connections.

Identify the function and location of each connection terminal using the wiring diagram on the corresponding section.

Intrinsically Safe conductors must be identified and segregated from non I.S. and wired in accordance to the relevant national/international installation standards (e.g. EN/IEC60079-14 Electrical apparatus for explosive gas atmospheres - Part 14: Electrical installations in hazardous areas (other than mines)), make sure that conductors are well isolated from each other and do not produce any unintentional connection. Isolation in accordance with EN/IEC 60079-11 clause 6.3.13 is provided between non-intrinsically safe circuits and intrinsically safe circuits. Isolation in accordance with EN/IEC 60079-11 clause 6.3.13 is not provided between separated intrinsically safe circuits.

Connect alarm contacts checking the load rating to be within the contact maximum rating 2 A 250 Vac 500 VA, 2 A 250 Vdc 80 W (resistive load).

**To prevent alarm relay contacts from damaging, connect an external protection (fuse or similar), chosen according to the relay breaking capacity diagram from installation instructions.**

The enclosure provides, according to EN60529, an IP20 minimum degree of protection (or similar to NEMA Standard 250 type 1). The equipment shall only be used in an area of at least pollution degree 2, as defined in IEC 60664-1. When installed in Zone 2, the unit shall be installed in an enclosure that provides a minimum ingress protection of IP54 in accordance with IEC 60079-0. When installed in a Class I, Zone 2 Hazardous Location, the unit shall be mounted in a supplemental AEx or Ex enclosure that provides a degree of protection not less than IP54 in accordance with UL/CSA 60079-0. When installed in a Class I, Division 2 Hazardous Location, the unit shall be mounted in a supplemental enclosure that provides a degree of protection not less than IP54. The enclosure must have a door or cover accessible only by the use of a tool. The end user is responsible to ensure that the operating temperature of the module is not exceeded in the end use application.

Units must be protected against dirt, dust, extreme mechanical (e.g. vibration, impact and shock) and thermal stress, and casual contacts. If enclosure needs to be cleaned use only a cloth lightly moistened by a mixture of detergent in water.

**Electrostatic Hazard: to avoid electrostatic hazard, the enclosure of D5232 series must be cleaned only with a damp or antistatic cloth.**

Any penetration of cleaning liquid must be avoided to prevent damage to the unit. Any unauthorized modification must be avoided.

D5232 series must be connected to SELV or PELV supplies.

All circuits connected to D5232 series must comply with the overvoltage category II (or better) according to EN/IEC60664-1.

**Warning: de-energize main power source (turn off power supply voltage) and disconnect plug-in terminal blocks before opening the enclosure to avoid electrical shock when connected to live hazardous potential.**

## Start-up

Before powering the unit check that all wires are properly connected, particularly supply conductors and their polarity, input and output wires, also check that Intrinsically Safe conductors and cable trays are segregated (no direct contacts with other non I.S. conductors) and identified either by color coding, preferably blue, or by marking.

Check conductors for exposed wires that could touch each other causing dangerous unwanted shorts.

Check that the module has been correctly configured through SWC5090 software. For details please see SWC5090 manual ISM0154.

Turn on power, the "power on" green LED must be lit, output signal must be in accordance with the corresponding input signal value and input/output chosen transfer function,

Status/fault LED should reflect the input variable condition with respect to configured settings. If possible change the sensor condition and check the corresponding Safe Area output.