

Warning

D5274 series are isolated Intrinsically Safe Associated Apparatus located in Non Hazardous Locations or Class I, Division 2, Groups A, B, C, D, Temperature Code T4 and Class I, Zone 2, Group IIC, IIB, IIA Temperature Code T4 Hazardous Locations within the specified operating temperature limits Tamb -40 to +70 °C, and connected to equipment with a maximum limit for power supply Um of 250 Vrms or Vdc. The module must be installed in an area of at least pollution degree 2, as defined in IEC 60664-1. When installed in a Class I, Zone 2 Hazardous Location, the unit shall be mounted in a supplemental AEx or Ex enclosure that provides a degree of protection not less than IP54 in accordance with UL/CSA 60079-0. When installed in a Class I, Division 2 Hazardous Location, the unit shall be mounted in a supplemental enclosure that provides a degree of protection not less than IP54. The enclosure must have a door or cover accessible only by the use of a tool. The end user is responsible to ensure that the operating temperature of the module is not exceeded in the end use application. Not to be connected to control equipment that uses or generates more than 250 Vrms or Vdc with respect to earth ground.

D5274 series must be installed, operated and maintained only by qualified personnel, in accordance to the relevant national/international installation standards (e.g. ANSI/ISA RP12.06.01 Installation of Intrinsically Safe System for Hazardous (Classified) Locations, National Electrical Code NEC ANSI/NFPA 70 Section 504 and 505, Canadian Electrical Code CEC) following the established installation rules, particular care shall be given to segregation and clear identification of I.S. conductors from non I.S. ones. Intrinsically safe circuits must be wired and separated in accordance with Article 504.20 of the National Electrical Code (ANSI/NFPA 70) or other local codes, as applicable.

De-energize power source (turn off power supply voltage) before plug or unplug the terminal blocks when installed in Hazardous Locations or unless area is known to be nonhazardous.

Warning: substitution of components may impair intrinsic safety. Avertissement: la substitution des composants peut nuire à la sécurité intrinsèque.

Explosion Hazard: to prevent ignition of flammable atmospheres, disconnect power before servicing or unless area is known to be nonhazardous.

Danger d'Explosion: pour prévenir une inflammation de l'atmosphère inflammable, couper l'alimentation avant de réparer à moins de savoir que l'emplacement n'est pas dangereux.

Units must be protected against dirt, dust, extreme mechanical (e.g. vibration, impact and shock) and thermal stress, and casual contacts.

If enclosure needs to be cleaned use only a cloth lightly moistened by a mixture of detergent in water.

Electrostatic Hazard: to avoid electrostatic hazard, the enclosure of D5274 must be cleaned only with a damp or antistatic cloth.

Danger électrostatique: pour éviter le danger électrostatique, l'enveloppe de la série D5274 doit être nettoyée au moyen d'un chiffon humide ou antistatique.

Any penetration of cleaning liquid must be avoided to prevent damage to the unit.

Failure to properly installation or use of the equipment may risk to damage the unit or severe personal injury.

The unit cannot be repaired by the end user and must be returned to the manufacturer or his authorized representative. Any unauthorized modification must be avoided.

Safety Description

Proc. Cont. Eq. for use in Class I, Division 2, Groups A, B, C, D, Temperature Code T4; Class I, Zone 2, AEx ec nC [ia Ga] IIC T4 Gc and Class I, Zone 2, Ex ec nC [ia Ga] IIC T4 Gc X Hazardous Locations. Provides intrinsically safe circuits for use in Class I, Division 1, Groups A, B, C, D; Class II, Division 1, Groups E, F, G; Class III, Division 1 and Class I, Zone 0, Group IIC; Zone 20, Group IIIC Hazardous Locations.

Approvals: refer to certificate n. E222308.

Connections for Temperature Sensors

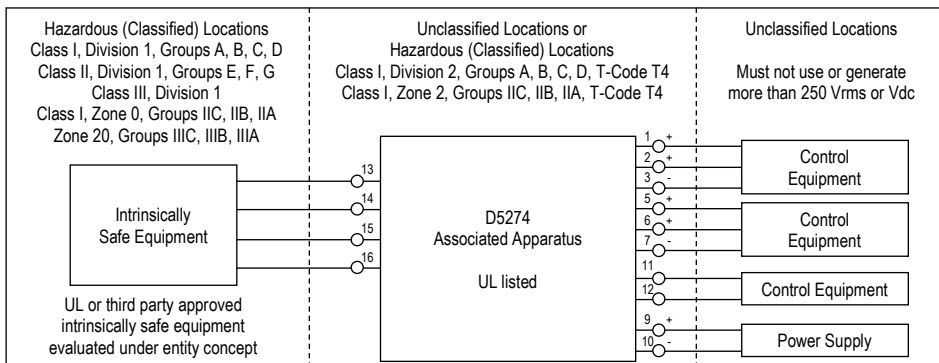

NOTE:

Connect only one individual conductor per each clamping point, use conductors up to 2.5 mm² (13 AWG) and a torque value of 0.5-0.6 Nm. Use only cables that are suitable for a temperature of at least 80°C.

This associated apparatus may also be connected to simple apparatus as defined in Article 504.2 and installed and temperature classified in accordance with article 504.10(B) of the National Electrical Code (ANSI/NFPA 70), or other local codes, as applicable.

Where multiple circuits extend from the same piece of associated apparatus, they must be installed in separate cables or in one cable having suitable insulation. Refer to Article 504.30(B) of the National Electrical Code (ANSI/NFPA 70) and Instrument Society of America Recommended Practice ISA RP12.6 for installing intrinsically safe equipment.

This associated apparatus has not been evaluated for use in combination with another associated apparatus.

Isolation in accordance with UL/CSA 60079-11 clause 6.3.13 is provided between non-intrinsically safe circuits and intrinsically safe circuits.

D5274 Terminals		Associated Apparatus Parameters	must be	Hazardous Area/Hazardous Locations Device Parameters
Ch1	13-14 -15-16	$U_o / V_{oc} = 7 \text{ V}$	\leq	U_i / V_{max}
		$I_o / I_{sc} = 22 \text{ mA}$	\leq	I_i / I_{max}
		$P_o / P_o = 38 \text{ mW}$	\leq	P_i / P_i

The output current of this associated apparatus is limited by a resistor such that the output voltage-current plot is straight line drawn between open-circuit voltage and short-circuit current.

D5274 Terminals		Associated Apparatus Parameters	must be	Hazardous Area/Hazardous Locations Device Parameters
Ch1	13-14 -15-16	$U_i / U_{max} = 20 \text{ V}$	\geq	U_o / V_{oc}
		$C_i = 4.5 \text{ nF}, L_i = 0 \text{ nH}$		

D5274 Terminals		Associated Apparatus Parameters		must be	Hazardous Area/Hazardous Locations Device + Cable Parameters
Ch1	13-14 -15-16	$C_o / C_a = 15.6 \mu\text{F}$ $C_o / C_a = 299 \mu\text{F}$ $C_o / C_a = 999 \mu\text{F}$ $C_o / C_a = 999 \mu\text{F}$	IIC (A, B) IIB (C) IIA (D) (E, F, G)	\geq	$C_i / C_i \text{ device} + C \text{ cable}$
		$L_o / L_a = 77.6 \text{ mH}$ $L_o / L_a = 310.6 \text{ mH}$ $L_o / L_a = 621.1 \text{ mH}$ $L_o / L_a = 1000 \text{ mH}$	IIC (A, B) IIB (C) IIA (D) (E, F, G)	\geq	$L_i / L_i \text{ device} + L \text{ cable}$
		$L_o / R_o = 954 \mu\text{H}/\Omega$ $L_o / R_o = 3818 \mu\text{H}/\Omega$ $L_o / R_o = 7636 \mu\text{H}/\Omega$ $L_o / R_o = 12528 \mu\text{H}/\Omega$	IIC (A, B) IIB (C) IIA (D) (E, F, G)	\geq	$L_i / R_i \text{ device and } L \text{ cable} / R \text{ cable}$

NOTE: for installations in which both the C_i and L_i of the Intrinsically Safe apparatus exceed 1 % of the C_o/C_a and L_o/L_a parameters of the Associated Apparatus (excluding the cable), then 50 % of C_o/C_a and L_o/L_a parameters are applicable and shall not be exceeded (50 % of the C_o/C_a and L_o/L_a become the limits which must include the cable such that $C_i \text{ device} + C \text{ cable} \leq 50 \% \text{ of } C_o/C_a$ and $L_i \text{ device} + L \text{ cable} \leq 50 \% \text{ of } L_o/L_a$). The reduced capacitance of the external circuit (including cable) shall not be greater than 1 μF for Groups C, D / IIA, IIB and 600 nF for Group A, B / IIC. Capacitance and inductance of the field wiring from the intrinsically safe equipment to the associated apparatus shall be calculated and must be included in the system calculations as shown in the entity parameters table. If the cable parameters are unknown, the following may be used: capacitance 60 pF per foot (200 pF per meter), inductance 0.20 μH per foot (1 μH per meter).

Alarm contact rating: 4 A 250 Vac 1000 VA with linear derating from 4 A (60 °C) down to 2 A (70 °C);
1 A 24 Vdc, 220 mA 125 Vdc, 110 mA 250 Vdc for UL.