

Characteristics:

General Description:

The single channel DIN Rail RS422 / RS485 Isolating Repeater type D1061S is used to separate Intrinsically Safe RS422 / RS485 equipment located in Hazardous Area from a RS232 / RS422 / RS485 controller located in Safe Area. Transmission speed is DIP-switch adjustable from 1.2 Kbit/s up to 1.5 Mbit/s. D1061S module supports all RS485 protocols, such as Fieldbus, Modbus, Profibus, etc. Terminating impedance is DIP-switch selectable inside the unit (250 Ω value) for both sides of communication lines (Hazardous Area and Safe Area side). RS422 / RS485 connection in Safe Area is provided both on terminal block and SUB D 9 poles female connector on the unit. RS232 connection is provided on SUB D 9 poles female connector only. The module also provides a shield terminal block for connecting cable shielding on Hazardous Area side.

Function:

1 channel IS RS422 / RS485 isolating repeater, provides 3 port isolation (in/out/supply).

Signaling LEDs:

Power supply indication (green), Rx-Tx transmission (yellow).

Field Configurability:

Hardware is totally configurable via DIP-switches; parameters are: transmission speed adjustable from 1.2 Kbit/s up to 1.5 Mbit/s; terminating impedance enabled or disabled in both communication lines; RS422 / RS485 connection selection from terminal block or SUB D 9 poles female connector.

EMC:

Fully compliant with CE marking applicable requirements.

Technical Data:

Supply:

24 Vdc nom (20 to 30 Vdc) reverse polarity protected, ripple within voltage limits ≤ 5 Vpp.

Current consumption @ 24 V: 100 mA with 1.5 Mbit/s transmission speed, typical.

Power dissipation: 2.0 W with 24 V supply and 1.5 Mbit/s transmission speed typical.

Max. power consumption: at 30 V supply and 1.5 Mbit/s transmission speed, 2.8 W.

Isolation (Test Voltage):

I.S. RS422-RS485 / RS232-RS422-RS485 1.5 KV; I.S. RS422-RS485 / Supply 1.5 KV; RS232-RS422-RS485 / Supply 500 V.

Input/Output I.S. Hazardous Area:

RS422 / RS485 Intrinsically Safe connection

(EIA RS422-A and EIA RS485 applicable standard).

Terminating impedance: 250 Ω DIP-switch selectable.

Transmission speed: 1.2, 2.4, 4.8, 9.6, 14.4, 19.2, 38.4, 57.6, 93.75, 115.2, 187.5, 375, 500, 750 Kbit/s or 1.0, 1.5 Mbit/s DIP-switch configurable.

Transmission cable length: ≤ 1200 m up to 93.75 Kbit/s, ≤ 1000 m up to 187.5 Kbit/s, ≤ 400 m up to 500 Kbit/s, ≤ 200 m up to 1.5 Mbit/s.

Connection: by plug-in disconnect screw terminal block to accommodate terminations up to 2.5 mm², shield terminal block provided for cable connection.

Output/Input Safe Area:

RS232 / RS422 / RS485 connection

(EIA RS232-C, EIA RS422-A and EIA RS485 applicable standard).

RS422 / RS485 Terminating impedance: 250 Ω DIP-switch selectable.

RS422 / RS485 Transmission speed: 1.2, 2.4, 4.8, 9.6, 14.4, 19.2, 38.4, 57.6, 93.75, 115.2, 187.5, 375, 500, 750 Kbit/s or 1.0, 1.5 Mbit/s DIP-switch configurable.

RS422 / RS485 Transmission cable length: ≤ 1200 m up to 93.75 Kbit/s, ≤ 1000 m up to 187.5 Kbit/s, ≤ 400 m up to 500 Kbit/s, ≤ 200 m up to 1.5 Mbit/s.

RS422 / RS485 Connection: by plug-in disconnect screw terminal block to accommodate terminations up to 2.5 mm² or SUB D 9 poles female connector (requires SUB D 9 poles male mating connector), DIP-switch configurable.

RS232 Transmission speed: 1.2, 2.4, 4.8, 9.6, 14.4, 19.2, 38.4, 57.6, 93.75, 115.2 Kbit/s DIP-switch configurable.

RS232 Transmission cable length: ≤ 15 m up to 115.2 Kbit/s.

RS232 Connection: SUB D 9 poles female connector (requires SUB D 9 poles male mating connector).

Compatibility:

CE mark compliant, conforms to Directives:

2014/34/EU ATEX, 2014/30/EU EMC, 2014/35/EU LVD, 2011/65/EU RoHS

Environmental conditions:

Operating: temperature limits -20 to +60 °C,

relative humidity max 90 % non condensing, up to 35 °C.

Storage: temperature limits -45 to +80 °C.

Safety Description:



ATEX: II (1)G [Ex ia Ga] IIC, II (1)D [Ex ia Da] IIIC, I (M1) [Ex ia Ma] I, II 3G Ex ec IIC T4 Gc

IECEx: [Ex ia Ga] IIC, [Ex ia Da] IIIC, [Ex ia Ma] I, Ex ec IIC T4 Gc

FM: NI / I / 2 / ABCD / T4, AIS / I, II, III / 1 / ABCDEFG

FM-C: NI / I / 2 / ABCD / T4, AIS / I, II, III / 1 / ABCDEFG

associated electrical apparatus.

Uo/Voc = 3.7 V, Io/Isc = 225 mA, Po/Po = 206 mW at terminals 13-14, 15-16.

Ui/Vmax = 30 V, li/lmax = 282 mA, Ci = 0 nF, Li = 0 nH at terminals 13-14, 15-16.

Um = 250 Vrms, -20 °C \leq Ta \leq 60 °C.

Approvals:

Presafe 16ATEX8917 conforms to EN60079-0, EN60079-11, EN50303.

IECEx PRE 16.0084 conforms to IEC60079-0, IEC60079-11.

IMQ 09 ATEX 013 X conforms to EN60079-0, EN60079-7.

IECEx IMQ 13.0011X conforms to IEC60079-0, IEC60079-7.

FM & FM-C No. 3024643, 3029921C, conforms to Class 3600, 3610, 3611, 3810,

ANSI/ISA 12.12.02, ANSI/ISA 60079-0, ANSI/ISA 60079-11, C22.2 No.142,

C22.2 No.157, C22.2 No.213, E60079-0, E60079-11, E60079-15,

DNV No. TAA00002BM and KR No.MIL20769-EL001 Cert. for maritime applications.

Mounting:

EN/IEC60715 TH 35 DIN-Rail.

Weight: about 170 g.

Connection: by polarized plug-in disconnect screw terminal blocks to accommodate terminations up to 2.5 mm² and SUB D 9 poles (DB9) DIN 41652 female connector (only for RS232, RS422, RS485 Safe Area connection).

Location: Safe Area/Non Hazardous Locations or Zone 2, Group IIC T4, Class I, Division 2, Groups A, B, C, D Temperature Code T4 and Class I, Zone 2, Group IIC, IIB, IIA T4 installation.

Protection class: IP 20.

Dimensions: Width 22.5 mm, Depth 99 mm, Height 114.5 mm.

Front Panel and Features:

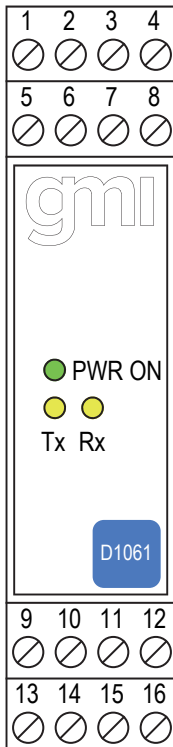

- Input/Output from Zone 0 (Zone 20), Division 1, installation in Zone 2, Division 2.
- RS422 / RS485 Hazardous Area I.S. Signal.
- RS232 / RS422 / RS485 Safe Area Signal.
- Transmission speed up to 1.5 Mbit/s.
- For Modbus, Fieldbus, Profibus and all other RS485 protocols.
- Three port isolation, Input/Output/Supply.
- EMC Compatibility to EN61000-6-2, EN61000-6-4.
- In-field programmability by DIP Switch.
- ATEX, IECEx, FM & FM-C Certifications.
- Type Approval Certificate DNV and KR for maritime applications.
- High Reliability, SMD components.
- Simplified installation using standard DIN Rail and plug-in terminal blocks.
- 250 Vrms (Um) max. voltage allowed to the instruments associated with the barrier.

Ordering Information:

Model:	D1061S
Power Bus enclosure	/B

Parameters Table:

Safety Description	Maximum External Parameters			
	Group Cenelec	Co/Ca (μF)	Lo/La (mH)	Lo/Ro (μH/Ω)
Terminals 13-14, 15-16				
Uo/Voc = 3.7 V	IIC	100	0.7	173
Io/Isc = 225 mA	IIB	1000	2.8	693
Po/Po = 206 mW	IIA	1000	5.6	1386
Ui/Vmax = 30 V	I	1000	11.75	2274
Ii/Imax = 282 mA	IIIC	1000	2.8	693
Ci = 0 nF, Li = 0 nH				

NOTE for USA and Canada:

IIC equal to Gas Groups A, B, C, D, E, F and G

IIB equal to Gas Groups C, D, E, F and G

IIA equal to Gas Groups D, E, F and G

Image:



Function Diagram:

HAZARDOUS AREA ZONE 0 (ZONE 20) GROUP IIC,
HAZARDOUS LOCATIONS CLASS I, DIVISION 1, GROUPS A, B, C, D,
CLASS II, DIVISION 1, GROUPS E, F, G, CLASS III, DIVISION 1,
CLASS I, ZONE 0, GROUP IIC

SAFE AREA, ZONE 2 GROUP IIC T4,
NON HAZARDOUS LOCATIONS, CLASS I, DIVISION 2,
GROUPS A, B, C, D T-Code T4, CLASS I, ZONE 2, GROUP IIC T4

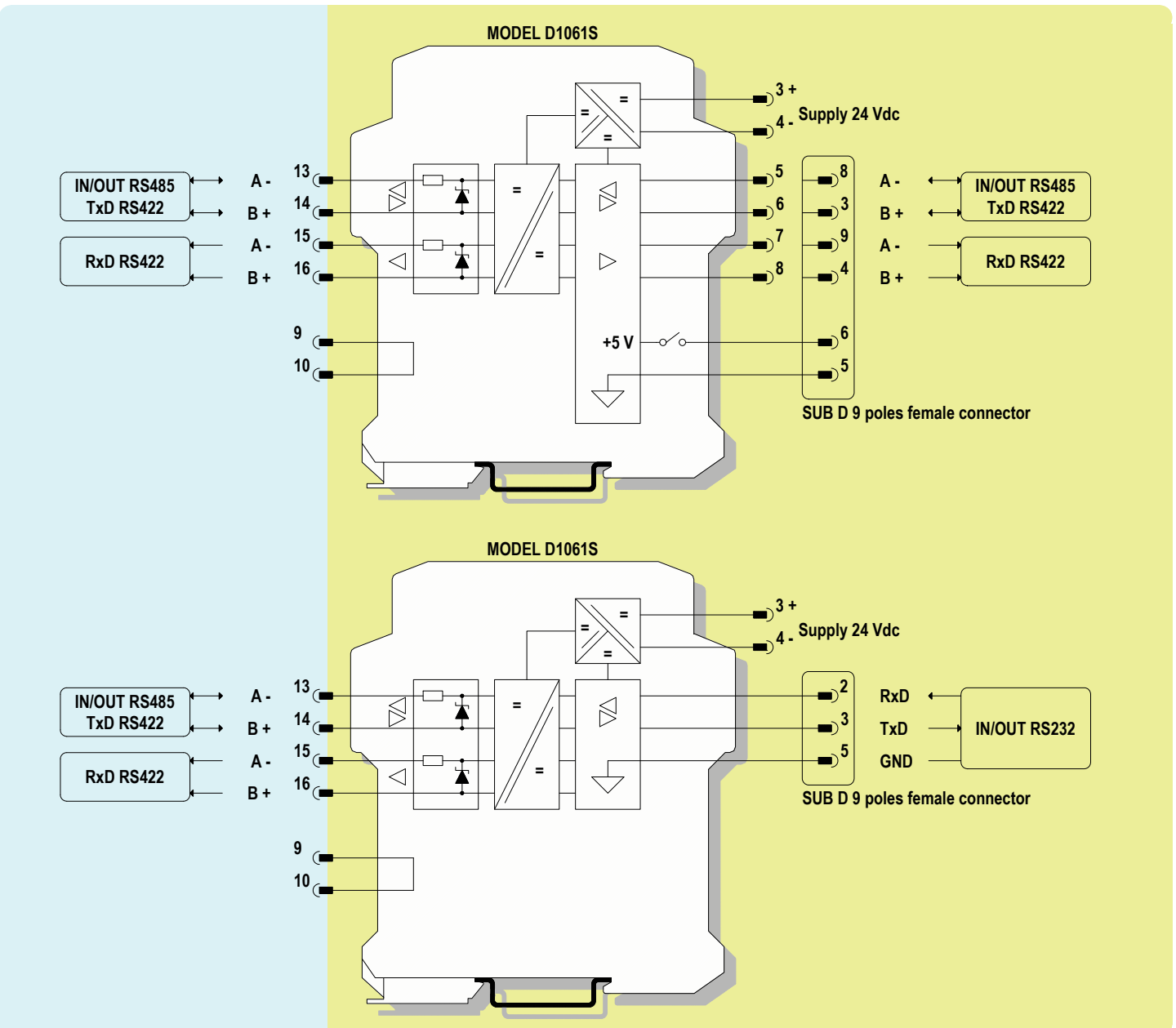

Function Diagram:

HAZARDOUS AREA ZONE 0 (ZONE 20) GROUP IIC,
HAZARDOUS LOCATIONS CLASS I, DIVISION 1, GROUPS A, B, C, D,
CLASS II, DIVISION 1, GROUPS E, F, G, CLASS III, DIVISION 1,
CLASS I, ZONE 0, GROUP IIC

SAFE AREA, ZONE 2 GROUP IIC T4,
NON HAZARDOUS LOCATIONS, CLASS I, DIVISION 2,
GROUPS A, B, C, D T-Code T4, CLASS I, ZONE 2, GROUP IIC T4

MODEL D1061S

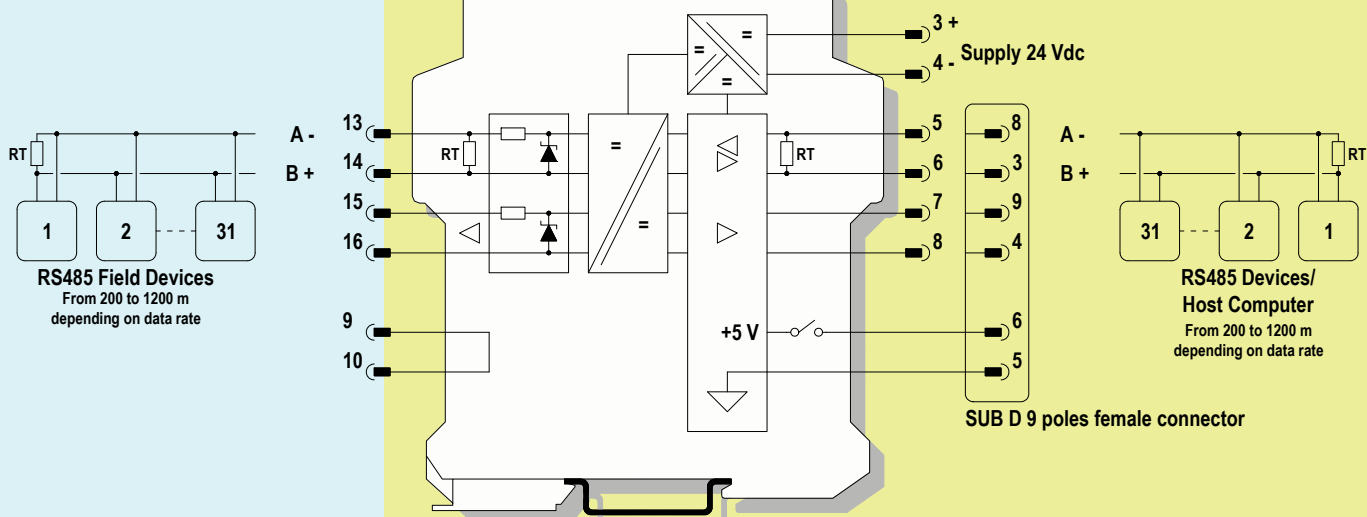

MODEL D1061S

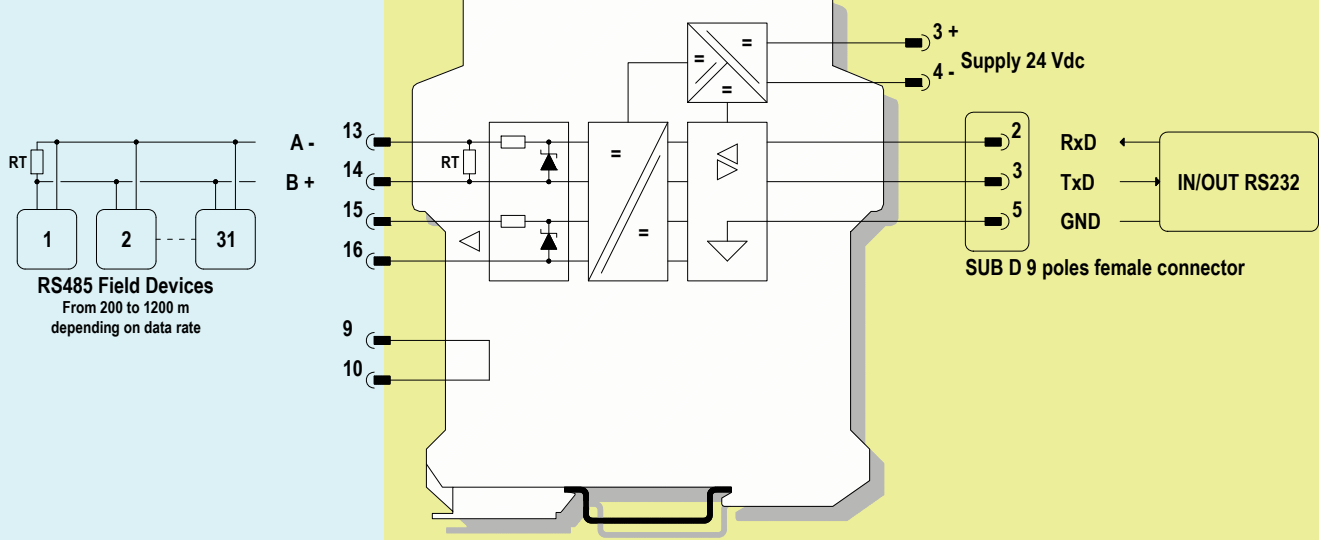

Function Diagram:

HAZARDOUS AREA ZONE 0 (ZONE 20) GROUP IIC,
HAZARDOUS LOCATIONS CLASS I, DIVISION 1, GROUPS A, B, C, D,
CLASS II, DIVISION 1, GROUPS E, F, G, CLASS III, DIVISION 1,
CLASS I, ZONE 0, GROUP IIC

SAFE AREA, ZONE 2 GROUP IIC T4,
NON HAZARDOUS LOCATIONS, CLASS I, DIVISION 2,
GROUPS A, B, C, D T-Code T4, CLASS I, ZONE 2, GROUP IIC T4

