

Characteristics:

General Description:

The Power Supply type PSW1250 is stainless steel AISI 304 unit. The Supply provides 24Vdc, 50 A output. PSW1250 unit can be paralleled, with load sharing circuits, which distribute current load equally to each power supply to increase reliability and reduce internal power dissipation. The Supply accepts AC power sources with nominal voltage range 110 to 240 Vac ($\pm 10\%$).

Overvoltage protection: 3 independent overvoltage protections: 1 voltage limiting loop at 30 Vdc and 1+1 crowbars at 30 Vdc.

EMC: Fully compliant with CE marking applicable requirements.

High load fuses breaking capability:

In case of short circuit on the load, the Power supply system delivers a very high peak current (about 800 Amp) for a duration of 0.5 ms. This characteristic ensures the instant breakage of the protective fuse or circuit breaker. Because of the very short peak current duration, other equipment connected to the load are not affected by the failure event and continue to operate without interruption.

Functional Safety Management Certification:

G.M. International is certified by TÜV to conform to IEC61508:2010 part 1 clauses 5-6 for safety related systems up to and included SIL3.

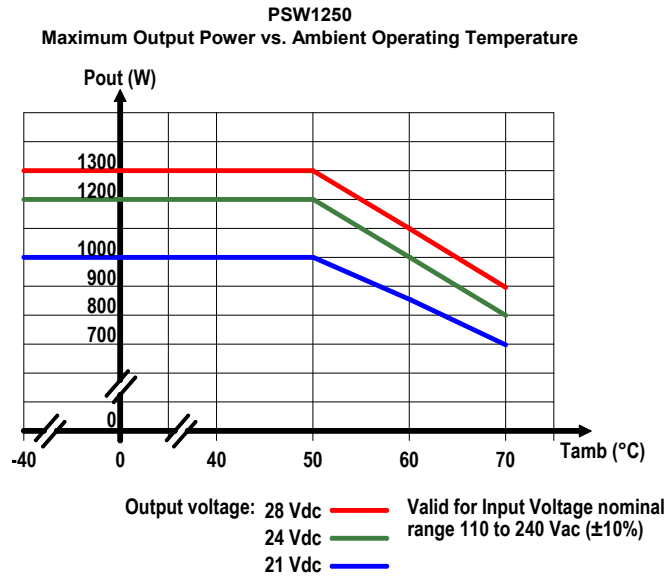

With 50% redundant configuration (two PSW1250 with paralleled outputs), each module can give 600 W power output up to 70°C operating ambient temperature, with output voltage range 21-28 Vdc and input voltage nominal range 110+240 Vac ($\pm 10\%$).

Features:

- SIL 3 for NE Load according IEC 61508:2010, with single PSW1250 module or more PSW1250 modules in redundant configuration (see ISM0220 for more information).
- SIL 1 for ND Load according to IEC 61508:2010, with single PSW1250 module (see ISM0220 for more information).
- SIL 2 for ND Load according IEC 61508:2010, with more PSW1250 modules in redundant configuration (see ISM0220 for more information).
- Systematic capability SIL 3.
- Power factor correction.
- Installation in Zone 2/Div. 2 hazardous locations.
- EMC Compatibility to EN61000-6-2, EN61000-6-4.
- ATEX, IECEx, UL & C-UL, TÜV Certification.
- TÜV Functional Safety Certification.
- Tested for maritime applications.
- Highly regulated output of 24 Vdc, 50 A, for PSW1250 module.
- Under and over voltage alarm monitoring.
- 3 over voltage redundant protections.
- Redundant parallel connections with load sharing.
- Reduces Power dissipation (in parallel/redundant configuration) by replacing a Schottky diode with Mosfet Active Ideal Diode.
- 89% efficiency @230 Vac input and 24 Vdc output and full load.
- Fan speed control depending on ambient temperature and output power.
- High load fuse breaking capability without interrupting operations.
- Tropicalization for electronic components.

Ordering Information:

Model: PSW1250

PSW1250 Technical Data:

Supply:

AC Input voltage: nominal 110 to 240 Vac ($\pm 10\%$), with frequency range 48 to 62 Hz.
Power Factor Correction (AC input): 0.98 typ. @230Vac, 0.995 typ. @115Vac, full load.
Efficiency @24Vdc out (full load): better than 89 % @ 230 Vac and 86% @ 115 Vac.
Max. internal power dissipation @24Vdc out (full load): 150 W @ 230 Vac; 195 W @ 115 Vac.

AC input current (sinusoidal at full load) @24Vdc out: 14.2 A @ 100 Vac input voltage, 12.2 A @ 115 Vac input voltage, 6.1 A @ 230 Vac input voltage.
Inrush current: 37 A peak @ 264 Vac; 32 A peak @ 230 Vac; 16 A peak @ 115 Vac.
AC input connection: screw terminal blocks suitable for 4mm² wires.

Isolation:

Input to Output isolation: 2500 Vrms (routine test).
Input to Earth-Ground isolation: 1500 Vrms (routine test).
Earth-Ground to Output isolation: 500 Vrms (routine test).
Output or Earth-Ground to Fault contact isolation: 500 Vrms (routine test).

Output:

Output voltage: 24 Vdc (adjustable from 21 to 28 Vdc).
Regulation: 0.4 % for a 100 % load change.
Stability: 0.01 % for a 20 % line voltage change.
Ripple: ≤ 250 mVpp.
Output current: 50 A nominal (@24Vdc out). Parallel connection for redundancy with load sharing capability within $\pm 5\%$ of output voltage setting.
Output power: up to 1300 W nominal (@28Vdc out).
Output Rise Time: 2.5 s.
Dynamic Response: 2 ms for 0-100% load change (overshoot $\pm 1.5\%$ of Vout setting).
Connection: M6 screw terminals on copper bars suitable for lug (at least 6.5 mm hole diameter) with 16mm² wire.
Hold-up time at full load: 20 ms (AC input).
Over voltage protection: output limited to 30 Vdc plus two redundant crowbars for over voltage protection at 30 Vdc.

Power good signaling:

Output good: $19.5 \text{ V} \leq \text{Vout} \leq 29.5 \text{ V}$.
Signaling: voltage free SPST normally energized relay (contact closed), de-energize in over/under voltage conditions (contact open).

Contact Rating: 2 A 50 Vac 100 VA, 2 A 24 Vdc 48 W (resistive load).

Connection: screw terminal blocks suitable for 2.5 mm² wires.

Compatibility:

CE mark compliant, conforms to Directive: 2014/34/EU ATEX, 2014/30/EU EMC, 2014/35/EU LVD, 2011/65/EU RoHS.

Environmental conditions:

Operating temperature limits: -40 to +70°C de-rated linearly 65-70% load above 50°C. (see Power Output vs. Ambient Operating Temperature diagram on this page).

Relative humidity limits: 95 %, up to 55°C.

Transport, storage temperature limits: - 45 to + 85 °C. **Max altitude:** 2000 m a.s.l.

Safety Description:



ATEX: II 3G Ex ec nC IIC T4 Gc. **IECEx:** Ex ec nC IIC T4 Gc.

UL: NI / I / 2 / ABCD / T4; **C-UL:** NI / I / 2 / ABCD / T4. **CCC:** Ex ec nC IIC T4 Gc

Approvals

BVS 15 ATEX E 006 X conforms to EN60079-0, EN60079-7, EN60079-11, EN60079-15.
IECEx BVS 15.0006X conforms to IEC60079-0, IEC60079-7, IEC60079-11, IEC60079-15.
UL & C-UL E498342 conforms to UL 61010-1, UL 121201 for UL and CAN/CSA C22.2 No.61010-1-12, CSA C22.2 No. 213 for C-UL.
CCC n. 2020322303000822 conforms to GB/T 3836.1, GB/T 3836.3, GB/T 3834.8
TÜV Certificate No. TÜV IT 25 SIL 0633 SIL 2 / SIL 3 conform to IEC 61508:2010 Ed. 2.
SIL 3 Functional Safety TÜV Certificate conforms to IEC61508:2010 Ed.2, for Management of Functional Safety.

Mechanical:

Mounting: Wall Mounting into a cabinet.

Weight: about 3.5 Kg.

Location: installation in Safe Area/Non Hazardous Locations or Zone 2, Group IIC T4 or Class I, Division 2, Group A,B,C,D, T4.

Protection class: IP 20, Open Type.

Dimensions: see drawings page 2.



Reasons for using an Ideal Diode-OR Controller circuit, in N+1 redundant power supply applications with high availability systems

High availability systems often employ power supply modules connected in parallel to achieve redundancy and enhance system reliability.

ORing diodes has been a popular means of connecting these supplies at a point of load. The disadvantage of this approach is the forward voltage drop and resulting efficiency loss. This drop reduces the available supply voltage and dissipates significant power.

Replacing Schottky diodes with N-channel MOSFETs reduces power dissipation and eliminates the need for expensive heat sinks or large thermal layouts in high power applications. In the Ideal Diode-OR Controller circuit (*active ideal diode*), the voltage across source and drain is monitored by IN and OUT pins, and GATE pin drives the MOSFETs to control their operation. In effect the MOSFET source and drain serve as the anode and cathode of an ideal diode.

In the event of a power supply failure, for example if the output of a fully loaded supply is suddenly shorted to ground, reverse current temporarily flows through the MOSFETs that are ON. This current is sourced from any load capacitance and from the other supplies. The active ideal diode quickly responds to this condition turning off the MOSFETs in about 0.5µs, thus minimizing disturbance and oscillations to the output bus.

Using ORing diodes, to parallel two, or more, 24VDC power supply modules for redundancy, one Schottky diode is used for each module. The voltage drop across the diode can reach about 0.8 V at 50 A, this means about 40 W dissipation for each module. Then, if two 50 A paralleled modules are used for full 50 + 50 A redundancy, a total power of about **80 W** is dissipated for this purpose. This reduces efficiency, reliability and increases space for heat sinks. Moreover, in case of module failure, diodes take time to recover and consequently they do not preserve the load from transients during the backup operation.

To avoid all these problems G.M. International has introduced, in the new PSW1250 Power Supply System, the use of *active ideal diodes*.

The MOSFETs resistance for *active ideal diodes* is about 1.2 mΩ resulting in 3.6 W dissipation for each power module. Then, if two 50 A paralleled modules are used for full 50 + 50 Amp redundancy, a total power of about **7.2 W** is dissipated for the purpose resulting in about **ten times less** dissipation compared to Schottky diodes solution.

This increases efficiency, reliability, availability and reduces space for heat sinks.

This circuit provides also very smooth voltage switchovers without oscillations with fast turnoff, minimizing reverse current transients.

Output voltage setting - Fault indications

The output voltage can be set to 24 Vdc +18%; -14% via a front panel trimmer.

Under voltage threshold is set to 19.5 V, while Over voltage threshold is set to 29.5 V.

A front panel power ON green LED signals that mains voltage is applied to the power module and normal DC output voltage is present on DC output bus.

Power module Fault conditions are signaled by opening contact of NE relay (in normal condition contact is closed), positioned on back board "Fault" terminal block. Faults can be:

- Under voltage $V_{out} < 19.5$ V.
- Over voltage $V_{out} > 29.5$ V.

In absence of under / over voltage fault, the green Power ON LED is ON if output voltage is within 19.5 V - 29.5 V range.

If output voltage goes below 19.5 V, the green Power ON LED blinks and holds this condition as long as output voltage goes over 20 V.

If output voltage goes over 29.5 V, the green Power ON LED is OFF and holds this condition as long as output voltage goes below 29 V.

After under / over voltage fault, coming back to normal condition, the green Power ON LED is ON if output voltage is within 20 V - 29 V range.

PSW1250 Wall Mounting into a cabinet - overall dimensions:

The PSW1250 is fixed to a vertical wall by means of four screws through four 6.50 mm diameter holes, shown in the following drawing with overall dimensions (mm).

In the position of two bottom screws there are two holes in the PCB with 13.00 mm diameter to allow crossing of screw head during screw installation.

The PSW1250 must only be installed as oriented in the following drawing.

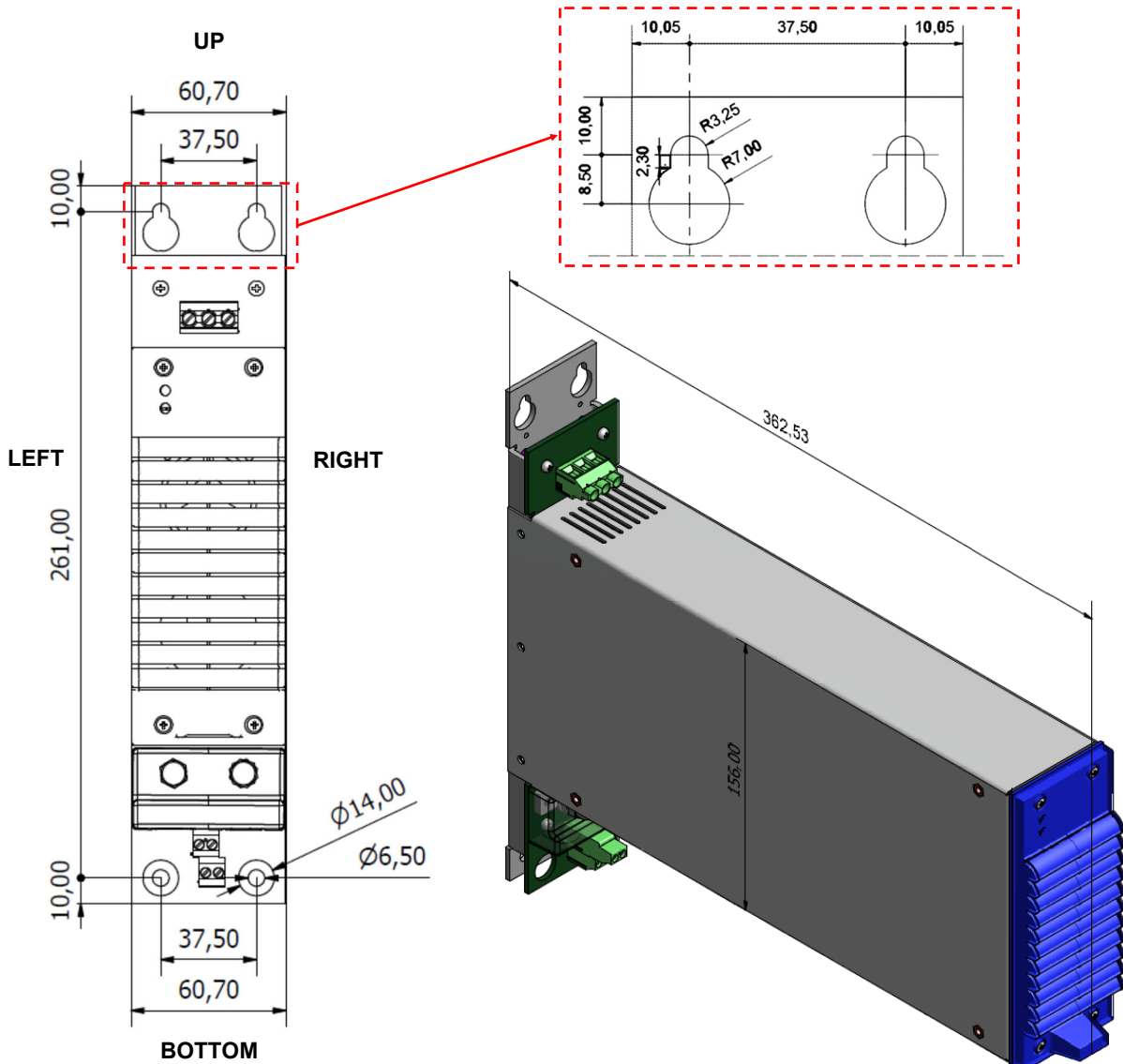

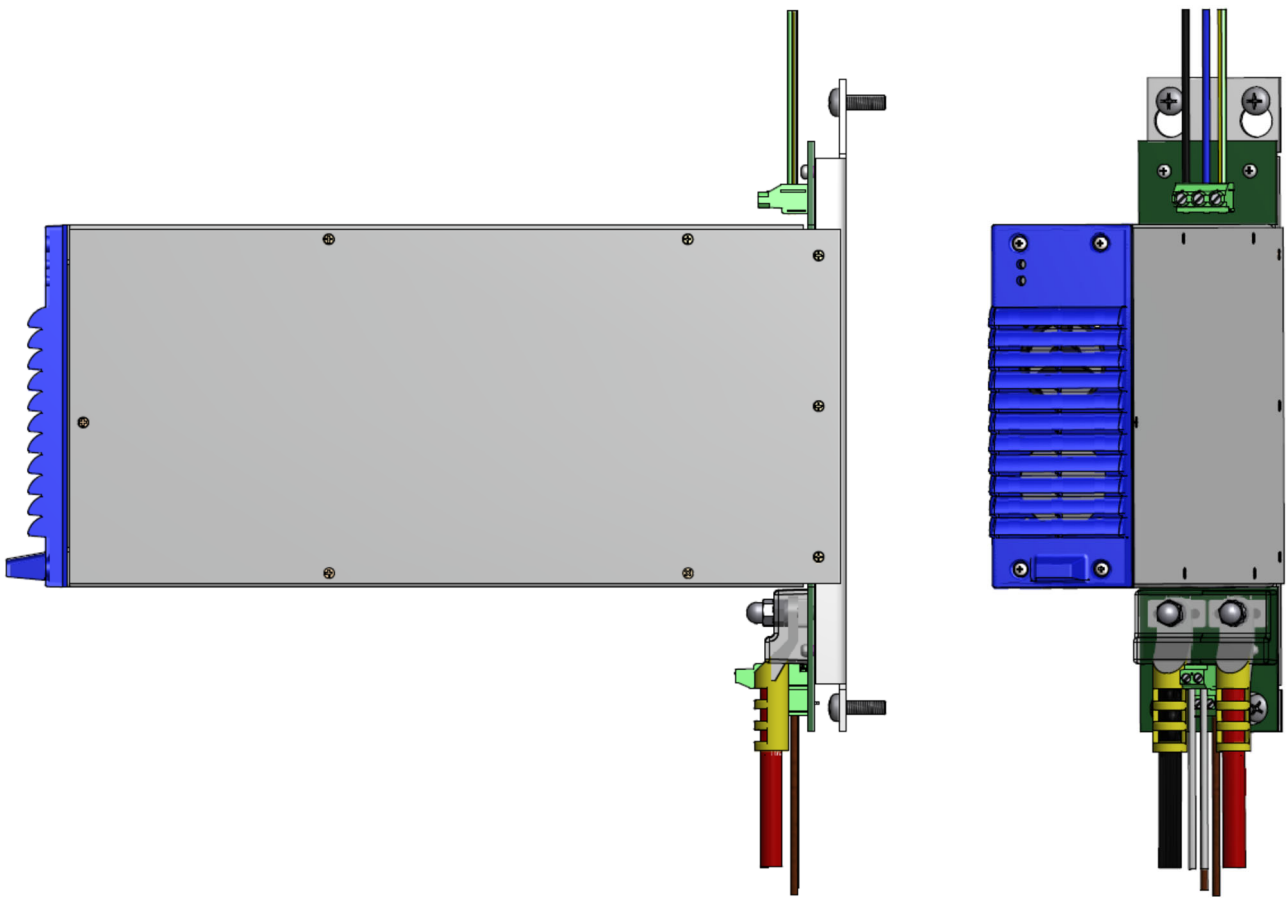

Function Diagram Dual AC Supply wiring architecture for PSW1250:

SAFE AREA or ZONE 2 GROUP IIC T4,
NON HAZARDOUS LOCATIONS or CLASS I, DIVISION 2, GROUPS A, B, C, D T-Code T4

PSW1250, dual AC supply, 1 redundant 50 A Output.

two modules connected in parallel to provide full redundancy on AC lines (AC1 and AC2) and one 50 A redundant output.

