

D5072-099

I.S. SIL2 Sink-Out Temperature Converter

The Sink-Out Temperature Converter D5072-099 accepts a low level dc signal from millivolt, thermocouple or resistance/RTD or transmitting potentiometer sensor, located in Hazardous Area, and converts, with isolation, the signal to drive a Safe Area load, suitable for applications requiring SIL 2 level in safety related systems for high risk industries. Output signal can be direct or reverse. Modbus RTU RS-485 output is available on Bus connector. Cold junction compensation can be programmed as Internal: provided by an internal PT1000 sensor; Fixed: to a user-customizable temperature value; External remote: ext. RTD placed away, on a support terminal board; External local: ext. RTD placed close to the module terminal block; Other: connecting compensation RTD to one of the two ch. For D5072D-099 module: duplicator function provides two independent outputs from one single input. Output function can be configured as: average, subtractor, low/high or redundancy selector. Modules are provided with alarm function, available via solid state contact output.

FEATURES

- SIL 2 / SC 3
- Input from Zone 0/Div. 1
- Installation in Zone 2/Div. 2
- mV, TC, 2/3/4wire res./RTD or potentiometer input
- Duplication/inversion/scaling/custom output
- Selectable CJC: internal PT1000, external RTD or fixed
- Burnout/internal/cjc/in sensor fault monitor
- Alarm output with user-settable trip points
- Modbus RTU RS-485 for monitor & configuration
- Fully programmable operating parameters
- High Accuracy, μ P controlled A/D converter
- Three port isolation, Input/Output/Supply
- High Density, two channels per unit

ORDERING INFORMATION

Ordering codes

D5072S-099: 1 channel

D5072D-099: 2 channels

Accessories

Bus Connector JDFT049, Bus Mounting Kit OPT5096.

Programmable USB serial line Kit PPC5092 + SWC5090.

OVERALL DIMENSIONS

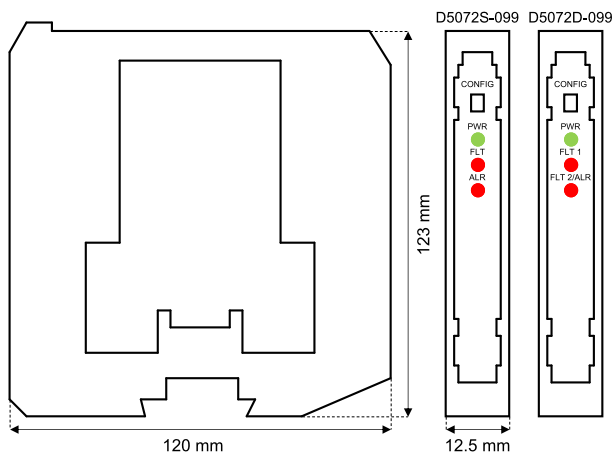

TECHNICAL DATA

Supply

24 Vdc nom (18 to 30 Vdc), reverse polarity protected.

Current consumption: 50 mA (D5072D-099), 42 mA (D5072S-099), @ 24 Vdc with 20 mA output, typical.

Power dissipation: 1.0 W (D5072D-099), 0.9 W (D5072S-099), @ 24 Vdc with 20 mA output, typical.

Input

Millivolt, thermocouple, 2-3-4 wire RTD or 3 wire transmitting potentiometer. Refer to Instruction Manual for more details.

Integration time: from 50 ms to 500 ms.

Input range: ± 500 mV (TC/mV), 0-4 k Ω (RTD/res), up to 10 k Ω (pot).

Thermocouple reference junction compensation: programmable: internal Pt1000, fixed, external, or remote.

Output

Fully customizable 0/4 to 20 mA (sink mode), current limited @ 24 mA. External voltage generator range is V min. 3.5V @ 0 Ω load and V max. 30V. Refer to Instruction Manual for more details.

Modbus interface

Modbus RTU RS-485 up to 115.2 kbps for monitor/configuration/control.

Performance

Ref. Conditions: 24 V supply, 250 Ω load, 23 \pm 1 $^{\circ}$ C ambient temperature, slow integration mode, 3/4-wires RTD.

Input:

Calibration & linearity accuracy: refer to Instruction Manual.

Temp. influence: refer to Instruction Manual.

Ref. junction compensation accuracy: $\leq \pm 3$ $^{\circ}$ C (internal CJC), $\leq \pm 1.5$ $^{\circ}$ C (external local CJC), according to RTD (external remote CJC). Refer to Instruction Manual.

Out:

Calibration accuracy: $\leq \pm 10$ μ A.

Linearity accuracy: $\leq \pm 10$ μ A.

Temp. influence: $\leq \pm 2$ μ A/ $^{\circ}$ C.

Isolation

I.S. In/Out 2.5 kV; I.S. In/Supply 2.5 kV; I.S. In/I.S. In 500 V; Out/Supply 500 V; Out/Out 500 V.

Environmental conditions

Operating temperature: temperature limits -40 to $+70$ $^{\circ}$ C.

Storage temperature: temperature limits -45 to $+80$ $^{\circ}$ C.

Safety description

Associated apparatus and non-sparking electrical equipment.

D5072S-099: $U_o = 7.2$ V, $I_o = 23$ mA, $P_o = 40$ mW, $U_i = 12.8$ V, $C_i = 0$ nF, $L_i = 0$ nH at terminals 7-8-9-10.

D5072D-099: $U_o = 7.2$ V, $I_o = 16$ mA, $P_o = 27$ mW, $U_i = 12.8$ V, $C_i = 0$ nF, $L_i = 0$ nH at terminals 7-8-9, 10-11-12.

$U_m = 250$ Vrms or Vdc, -40 $^{\circ}$ C $\leq T_a \leq 70$ $^{\circ}$ C.

Mounting

DIN-Rail 35 mm, with or without Power Bus or on custom Term. Board.

Weight: about 135 g (D5072D-099), 130 g (D5072S-099).

Connection: by polarized plug-in disconnect screw terminal blocks to accommodate terminations up to 2.5 mm² (13 AWG).

Dimensions: Width 12.5 mm, Depth 123 mm, Height 120 mm.

FUNCTION DIAGRAM

Additional installation diagrams may be found in Instruction Manual.

Hazardous Area

Safe Area/Zone 2/Div. 2

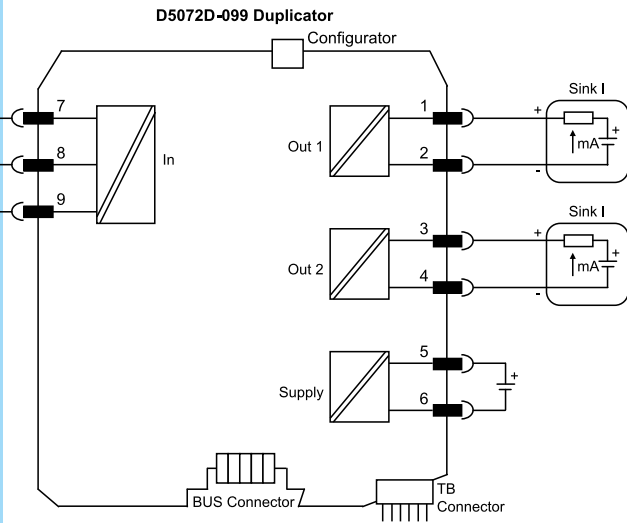
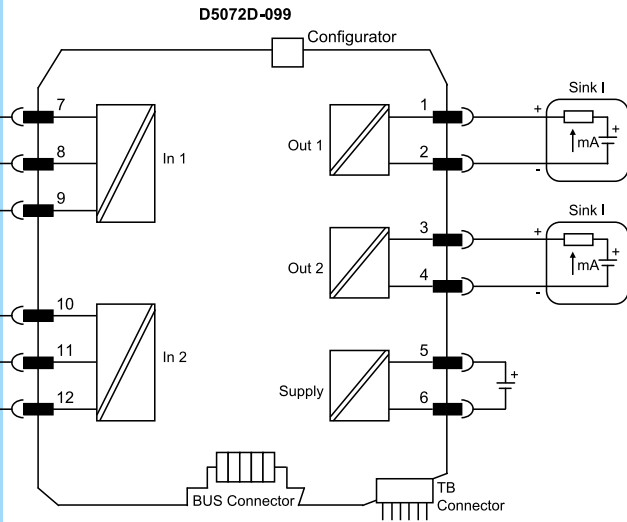
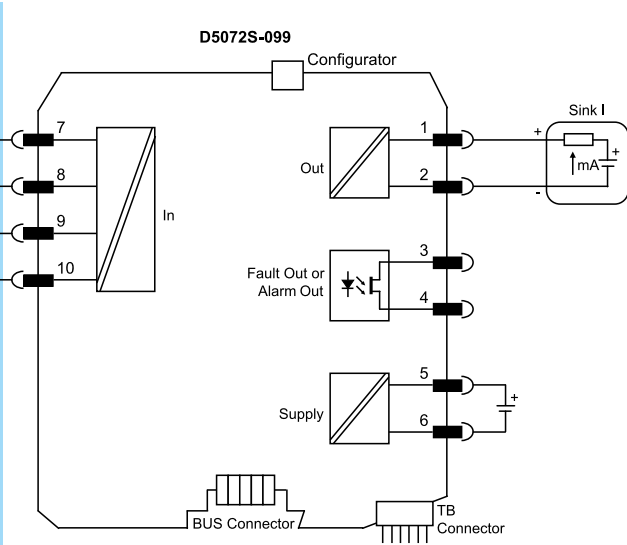
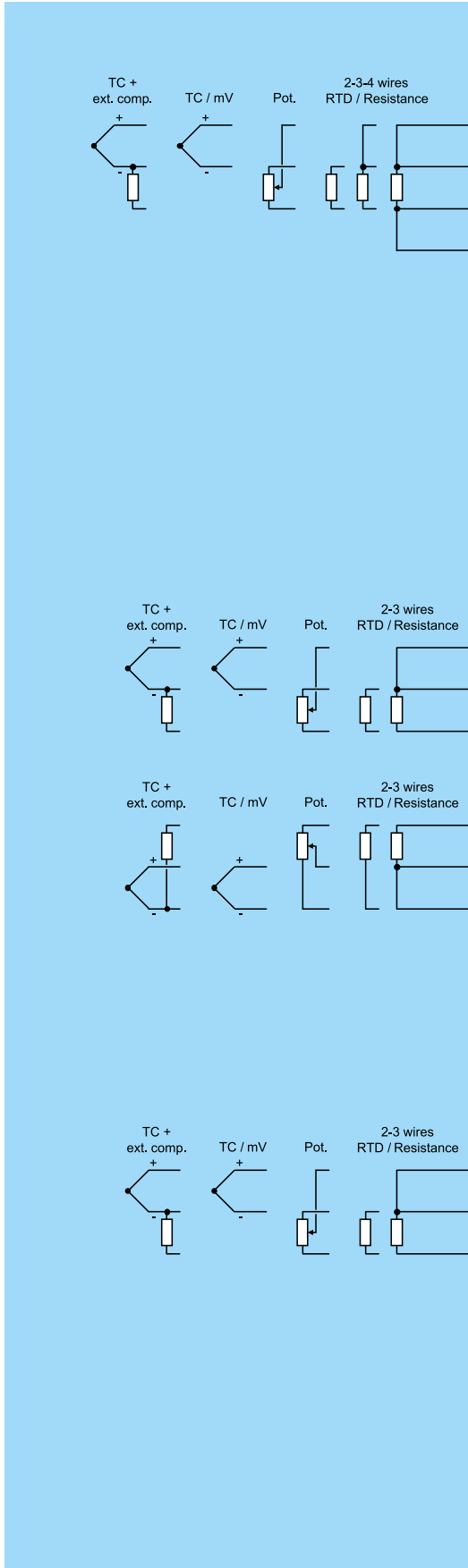

FSM SIL 3 Functional Safety Management Certification: GM International is certified to conform to IEC61508:2010 part 1 clauses 5-6 for safety related systems up to and included SIL3. In addition, GM International products have been granted I.S. certificates from the most credited Notified Bodies in the world.

Data specified in this document are merely descriptive of the products and should be integrated with relevant technical specifications. Our products are in constant development and the information presented herein refers to the time of document issue. No statements concerning a certain condition or suitability for a certain application can be derived from our information. The information given does not release the user from the obligation of own judgment and verification. Terms & Conditions can be found at our website. For more information refer to instruction manual.