



INSTRUCTION MANUAL

RS422/RS485 Fieldbus
Isolating Repeater
Din-Rail Model D1061S

Characteristics

General Description: The single channel DIN Rail RS422 / RS485 Fieldbus Isolating Repeater type D1061S is used to separate Intrinsically Safe RS422 / RS485 equipment located in Hazardous Area from a RS232 / RS422 / RS485 controller located in Safe Area. Transmission speed is DIP-switch adjustable from 1.2 Kbit/s up to 1.5 Mbit/s. Terminating impedance is DIP-switch selectable inside the unit (250 Ω value) for both sides of communication lines (Hazardous Area and Safe Area side). RS422 / RS485 connection in Safe Area is provided both on terminal block and SUB D 9 poles female connector on the unit. RS232 connection is provided on SUB D 9 poles female connector only. The module also provides a shield terminal block for connecting cable shielding on Hazardous Area side.

Function: 1 channel I.S. RS422 / RS485 isolating repeater, provides 3 port isolation (input/output/supply).

Signalling LEDs: Power supply indication (green), Rx-Tx transmission (yellow).

Field Configurability: Hardware is totally configurable via DIP-switches; parameters are: transmission speed adjustable from 1.2 Kbit/s up to 1.5 Mbit/s; terminating impedance enabled or disabled in both communication lines; RS422 / RS485 connection selection from terminal block or SUB D 9 poles female connector.

EMC: Fully compliant with CE marking applicable requirements.

Technical Data

Supply: 24 Vdc nom (20 to 30 Vdc) reverse polarity protected, ripple within voltage limits ≤ 5 Vpp.

Current consumption @ 24 V: 100 mA with 1.5 Mbit/s transmission speed, typical.

Power dissipation: 2.0 W with 24 V supply and 1.5 Mbit/s transmission speed typical.

Max. power consumption: at 30 V supply and 1.5 Mbit/s transmission speed, 2.8 W.

Isolation (Test Voltage): I.S. RS422-RS485 / RS232-RS422-RS485 1.5 KV; I.S. RS422-RS485 / Supply 1.5 KV; RS232-RS422-RS485 / Supply 500 V.

Input/Output I.S. Hazardous Area: RS422 / RS485 Intrinsically Safe connection (EIA RS422-A and EIA RS485 applicable standard).

Terminating impedance: 250 Ω DIP-switch selectable.

Transmission speed: 1.2, 2.4, 4.8, 9.6, 14.4, 19.2, 38.4, 57.6, 93.75, 115.2, 187.5, 375, 500, 750 Kbit/s or 1.0, 1.5 Mbit/s DIP-switch configurable.

Transmission cable length: ≤ 1200 m up to 93.75 Kbit/s, ≤ 1000 m up to 187.5 Kbit/s, ≤ 400 m up to 500 Kbit/s, ≤ 200 m up to 1.5 Mbit/s.

Connection: by plug-in disconnect screw terminal block to accommodate terminations up to 2.5 mm², shield terminal block provided for cable connection.

Output/Input Safe Area: RS232 / RS422 / RS485 connection (EIA RS232-C, EIA RS422-A and EIA RS485 applicable standard).

RS422 / RS485 Terminating impedance: 250 Ω DIP-switch selectable.

RS422 / RS485 Transmission speed: 1.2, 2.4, 4.8, 9.6, 14.4, 19.2, 38.4, 57.6, 93.75, 115.2, 187.5, 375, 500, 750 Kbit/s or 1.0, 1.5 Mbit/s DIP-switch configurable.

RS422 / RS485 Transmission cable length: ≤ 1200 m up to 93.75 Kbit/s, ≤ 1000 m up to 187.5 Kbit/s, ≤ 400 m up to 500 Kbit/s, ≤ 200 m up to 1.5 Mbit/s.

RS422 / RS485 Connection: by plug-in disconnect screw terminal block to accommodate terminations up to 2.5 mm² or SUB D 9 poles female connector (requires SUB D 9 poles male mating connector), DIP-switch configurable.

RS232 Transmission speed: 1.2, 2.4, 4.8, 9.6, 14.4, 19.2, 38.4, 57.6, 93.75, 115.2 Kbit/s DIP-switch configurable.

RS232 Transmission cable length: ≤ 15 m up to 115.2 Kbit/s.

RS232 Connection: SUB D 9 poles female connector (requires SUB D 9 poles male mating connector).

Compatibility:

 CE mark compliant, conforms to Directives:
2014/34/EU ATEX, 2014/30/EU EMC, 2014/35/EU LVD, 2011/65/EU RoHS

Environmental conditions:

Operating: temperature limits -20 to + 60 °C,
relative humidity max 90 % non condensing, up to 35 °C.

Storage: temperature limits - 45 to + 80 °C.

Safety Description:



ATEX: II (1)G [Ex ia Ga] IIC, II (1)D [Ex ia Da] IIC, I (M1) [Ex ia Ma] I, II 3G Ex ec IIC T4 Gc

IECEx: [Ex ia Ga] IIC, [Ex ia Da] IIC, [Ex ia Ma] I, Ex ec IIC T4 Gc

FM: NI / I / 2 / ABCD / T4, AIS / I, II, III / 1 / ABCDEFG

FM-C: NI / I / 2 / ABCD / T4, AIS / I, II, III / 1 / ABCDEFG

associated electrical apparatus.

Uo/Voc = 3.7 V, Io/Isc = 225 mA, Po/Po = 206 mW at terminals 13-14, 15-16.

Ui/Vmax = 30 V, Ii/IImax = 282 mA, Ci = 0 nF, Li = 0 nH at terminals 13-14, 15-16.

Um = 250 Vrms, -20 °C \leq Ta \leq 60 °C.

Approvals:

Presafe 16ATEX8917 conforms to EN60079-0, EN60079-11, EN50303.

IECEx PRE 16.0084 conforms to IEC60079-0, IEC60079-11.

IMQ 09 ATEX 013 X conforms to EN60079-0, EN60079-7.

IECEx IMQ 13.0011X conforms to IEC60079-0, IEC60079-7.

FM & FM-C No. 3024643, 3029921C, conforms to Class 3600, 3610, 3611, 3810,

ANSI/ISA 12.12.02, ANSI/ISA 60079-0, ANSI/ISA 60079-11, C22.2 No.142,

C22.2 No.157, C22.2 No.213, E60079-0, E60079-11, E60079-15,

DNV No. TAA00002BM and KR No.MIL20769-EL001 Cert. for maritime applications.

Mounting: EN/IEC60715 TH 35 DIN-Rail.

Weight: about 170 g.

Connection: by polarized plug-in disconnect screw terminal blocks to accommodate terminations up to 2.5 mm² and SUB D 9 poles (DB9) DIN 41652 female connector (only for RS232, RS422, RS485 Safe Area connection).

Location: Safe Area/Non Hazardous Locations or Zone 2, Group IIC T4,

Class I, Division 2, Groups A, B, C, D Temperature Code T4 and

Class I, Zone 2, Group IIC, IIB, IIA T4 installation.

Protection class: IP 20.

Dimensions: Width 22.5 mm, Depth 99 mm, Height 114.5 mm.

Ordering information

Model:	D1061S	
Power Bus enclosure		/B

Front Panel and Features

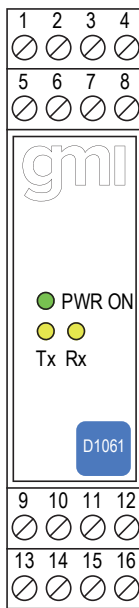

- Input/Output from Zone 0 (Zone 20), Division 1, installation in Zone 2, Division 2.
- RS422 / RS485 Hazardous Area I.S. Signal.
- RS232 / RS422 / RS485 Safe Area Signal.
- Transmission speed up to 1.5 Mbit/s.
- For Modbus, Fieldbus, Profibus and all other RS485 protocols.
- Three port isolation, Input/Output/Supply.
- EMC Compatibility to EN61000-6-2, EN61000-6-4.
- In-field programmability by DIP Switch.
- ATEX, IECEx, FM & FM-C Certifications.
- Type Approval Certificate DNV and KR for maritime applications.
- High Reliability, SMD components.
- Simplified installation using standard DIN Rail and plug-in terminal blocks.
- 250 Vrms (Um) max. voltage allowed to the instruments associated with the barrier.

Terminal block connections

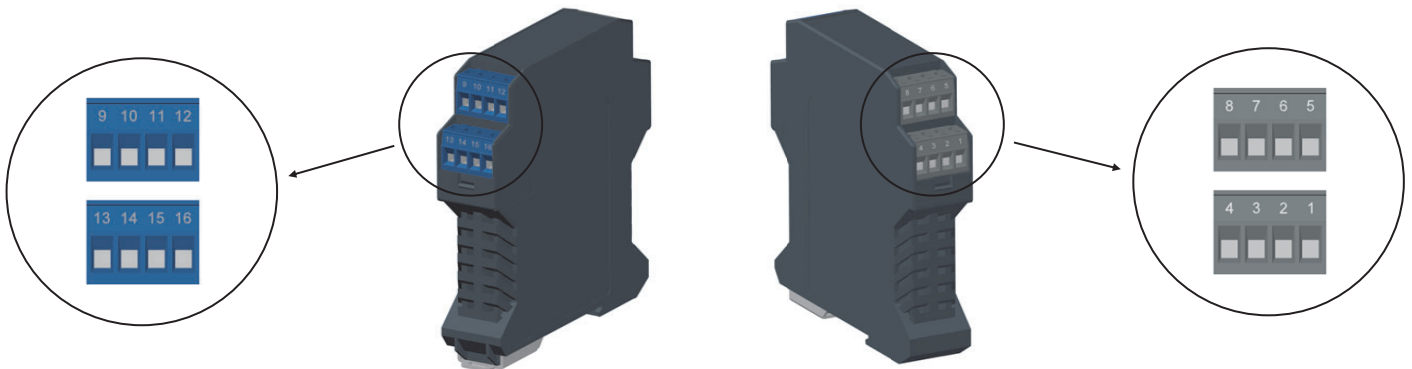

HAZARDOUS AREA

9	To shield
10	To shield
11	Not used
12	Not used
13	A - for IN/OUT RS485 or TxD RS422
14	B + for IN/OUT RS485 or TxD RS422
15	A - for RxD RS422
16	B - for RxD RS422

SAFE AREA

1	Not used
2	Not used
3	+ Power Supply 24 Vdc
4	- Power Supply 24 Vdc
5	A - for IN/OUT RS485 or TxD RS422
6	B + for IN/OUT RS485 or TxD RS422
7	A - for RxD RS422
8	B - for RxD RS422

Parameters Table

In the system safety analysis, always check the Hazardous Area/Hazardous Locations devices to conform with the related system documentation, if the device is Intrinsically Safe check its suitability for the Hazardous Area/Hazardous Locations and gas group encountered and that its maximum allowable voltage, current, power (U_i/V_{max} , I_i/I_{max} , P_i/P_i) are not exceeded by the safety parameters (U_o/V_{oc} , I_o/I_{sc} , P_o/P_o) of the D1061 series Associated Apparatus connected to it. Also consider the maximum operating temperature of the field device, check that added connecting cable and field device capacitance and inductance do not exceed the limits (C_o/C_a , L_o/L_a , L_o/R_o) given in the Associated Apparatus parameters for the effective gas group. See parameters on enclosure side and the ones indicated in the table below:

D1061 Terminals	D1061 Associated Apparatus Parameters	Must be	Hazardous Area/ Hazardous Locations Device Parameters
13 - 14 15 - 16	$U_o / V_{oc} = 3.7 V$	\leq	U_i / V_{max}
13 - 14 15 - 16	$I_o / I_{sc} = 225 mA$	\leq	I_i / I_{max}
13 - 14 15 - 16	$P_o / P_o = 206 mW$	\leq	P_i / P_i

D1061 Terminals	D1061 Associated Apparatus Parameters	Must be	Hazardous Area/ Hazardous Locations Device + Cable Parameters
13 - 14 15 - 16	$C_o / C_a = 100 \mu F$ (IIC-A, B) $C_o / C_a = 1000 \mu F$ (IIB-C) $C_o / C_a = 1000 \mu F$ (IIA-D) $C_o / C_a = 1000 \mu F$ (I) $C_o / C_a = 1000 \mu F$ (IIIC)	\geq	C_i / C_i device + C cable
13 - 14 15 - 16	$L_o / L_a = 0.7 mH$ (IIC-A, B) $L_o / L_a = 2.8 mH$ (IIB-C) $L_o / L_a = 5.6 mH$ (IIA-D) $L_o / L_a = 11.75 mH$ (I) $L_o / L_a = 2.8 mH$ (IIIC)	\geq	L_i / L_i device + L cable
13 - 14 15 - 16	$L_o / R_o = 173 \mu H/\Omega$ (IIC-A, B) $L_o / R_o = 693 \mu H/\Omega$ (IIB-C) $L_o / R_o = 1386 \mu H/\Omega$ (IIA-D) $L_o / R_o = 2274 \mu H/\Omega$ (I) $L_o / R_o = 693 \mu H/\Omega$ (IIIC)	\geq	L_i / R_i device and L cable / R cable

NOTE for USA and Canada:
 IIC equal to Gas Groups A, B, C, D, E, F and G
 IIB equal to Gas Groups C, D, E, F and G
 IIA equal to Gas Groups D, E, F and G

When used with separate powered intrinsically safe devices, check that maximum allowable voltage, current (U_i/V_{max} , I_i/I_{max}) of the D1061 Associated Apparatus are not exceeded by the safety parameters (U_o/V_{oc} , I_o/I_{sc}) of the Intrinsically Safe device, indicated in the table below:

D1061 Terminals	D1061 Associated Apparatus Parameters	Must be	Hazardous Area/ Hazardous Locations Device Parameters
13 - 14 15 - 16	$U_i / V_{max} = 30V$	\geq	U_o / V_{oc}
13 - 14 15 - 16	$I_i / I_{max} = 282 mA$	\geq	I_o / I_{sc}
13 - 14 15 - 16	$C_i = 0 nF, L_i = 0 nH$		

For installations in which both the C_i and L_i of the Intrinsically Safe apparatus exceed 1% of the C_o and L_o parameters of the Associated Apparatus (excluding the cable), then 50% of C_o and L_o parameters are applicable and shall not be exceeded (50% of the C_o and L_o become the limits which must include the cable such that C_i device + C cable \leq 50 % of C_o and L_i device + L cable \leq 50 % of L_o). The reduced capacitance of the external circuit (including cable) shall not be greater than 1 μF for Groups I, IIA, IIB and 600 nF for Group IIC. If the cable parameters are unknown, the following value may be used: Capacitance 200 pF per meter (60 pF per foot), Inductance 1 μH per meter (0.20 μH per foot). The Intrinsic Safety Entity Concept allows the interconnection of Intrinsically Safe devices approved with entity parameters not specifically examined in combination as a system when the above conditions are respected.

For Division 1 and Zone 0 installations, the configuration of Intrinsically Safe Equipment must be FM approved under Entity Concept (or third party approved); for Division 2 installations, the configuration of Intrinsically Safe Equipment must be FM approved under non-incendive field wiring or Entity Concept (or third party approved).

Function Diagram

HAZARDOUS AREA ZONE 0 (ZONE 20) GROUP IIC,
HAZARDOUS LOCATIONS CLASS I, DIVISION 1, GROUPS A, B, C, D,
CLASS II, DIVISION 1, GROUPS E, F, G, CLASS III, DIVISION 1,
CLASS I, ZONE 0, GROUP IIC

SAFE AREA, ZONE 2 GROUP IIC T4,
NON HAZARDOUS LOCATIONS, CLASS I, DIVISION 2,
GROUPS A, B, C, D T-Code T4, CLASS I, ZONE 2, GROUP IIC T4

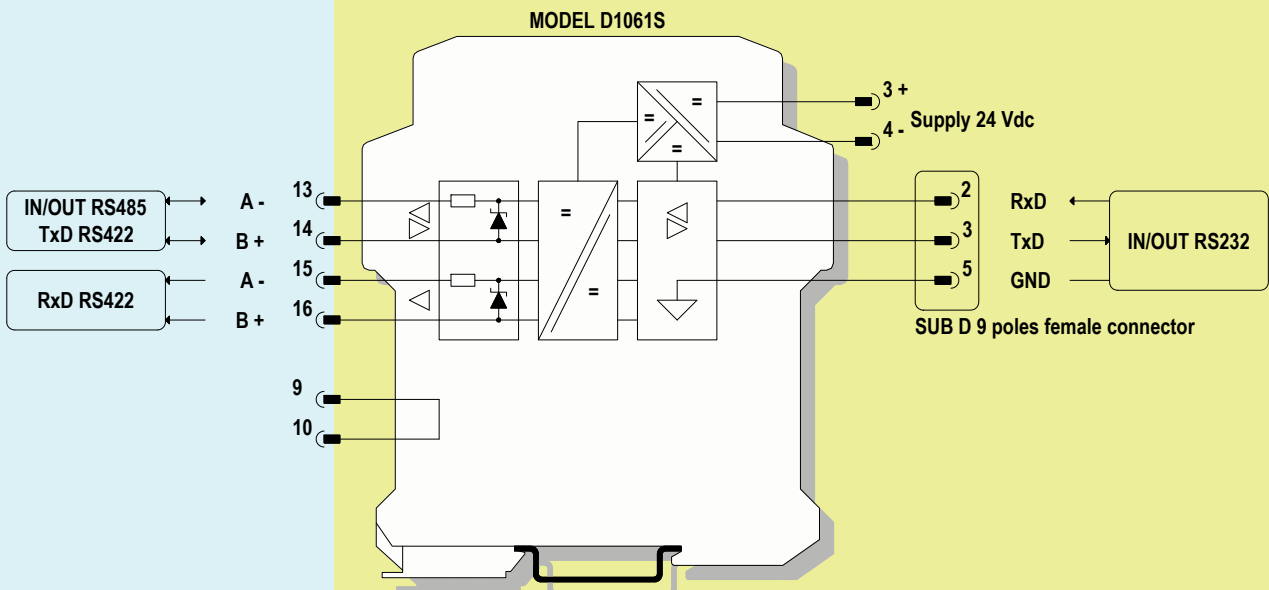
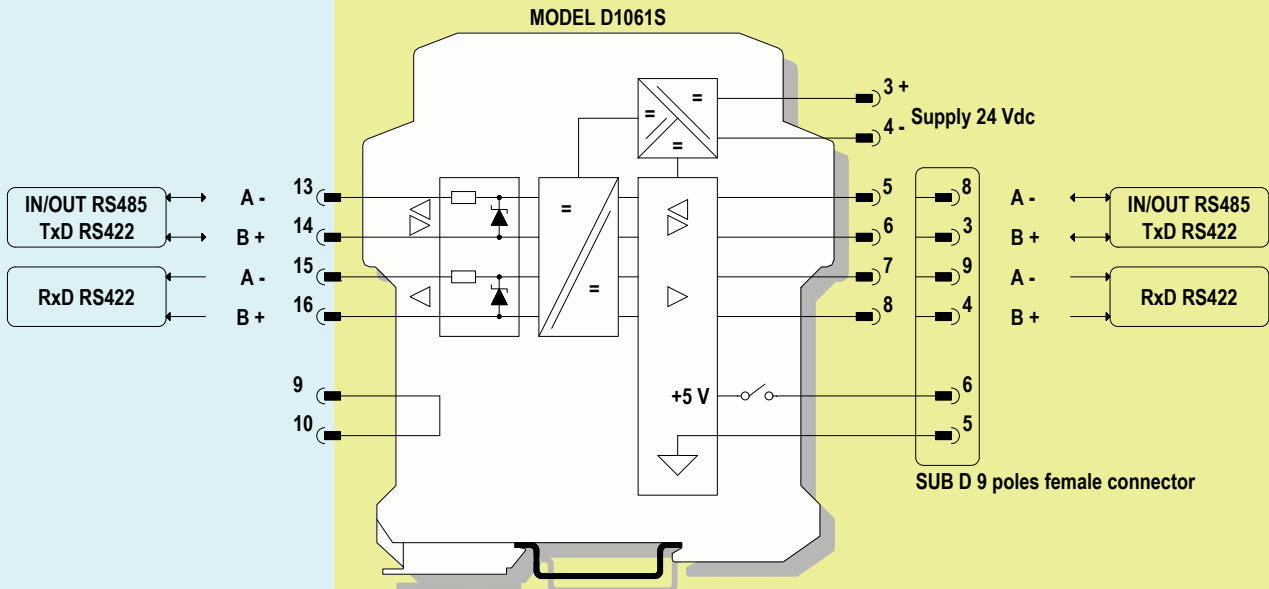

Function Diagram

HAZARDOUS AREA ZONE 0 (ZONE 20) GROUP IIC,
HAZARDOUS LOCATIONS CLASS I, DIVISION 1, GROUPS A, B, C, D,
CLASS II, DIVISION 1, GROUPS E, F, G, CLASS III, DIVISION 1,
CLASS I, ZONE 0, GROUP IIC

SAFE AREA, ZONE 2 GROUP IIC T4,
NON HAZARDOUS LOCATIONS, CLASS I, DIVISION 2,
GROUPS A, B, C, D T-Code T4, CLASS I, ZONE 2, GROUP IIC T4

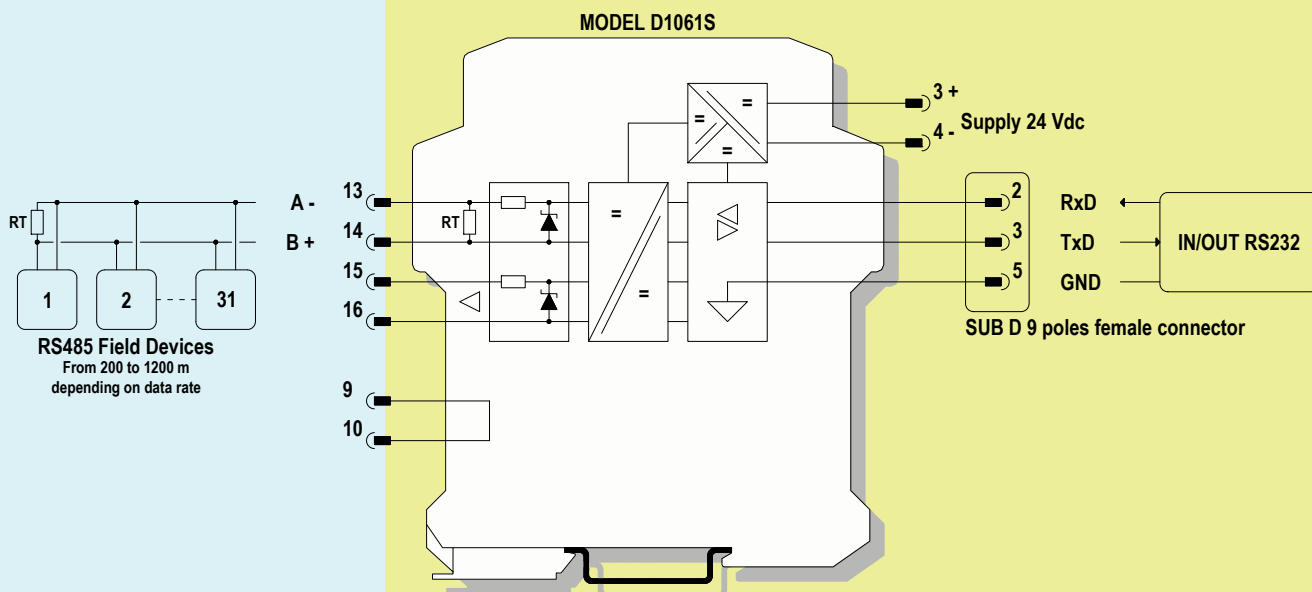
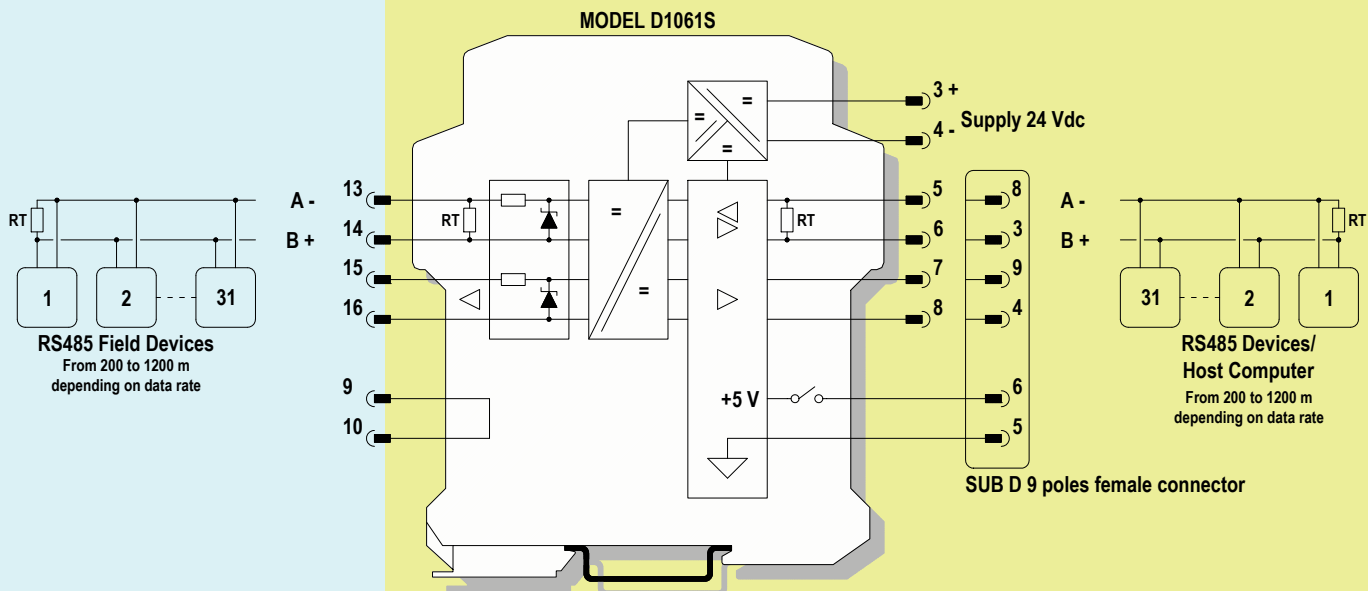

Function Diagram

HAZARDOUS AREA ZONE 0 (ZONE 20) GROUP IIC,
HAZARDOUS LOCATIONS CLASS I, DIVISION 1, GROUPS A, B, C, D,
CLASS II, DIVISION 1, GROUPS E, F, G, CLASS III, DIVISION 1,
CLASS I, ZONE 0, GROUP IIC

SAFE AREA, ZONE 2 GROUP IIC T4,
NON HAZARDOUS LOCATIONS, CLASS I, DIVISION 2,
GROUPS A, B, C, D T-Code T4, CLASS I, ZONE 2, GROUP IIC T4

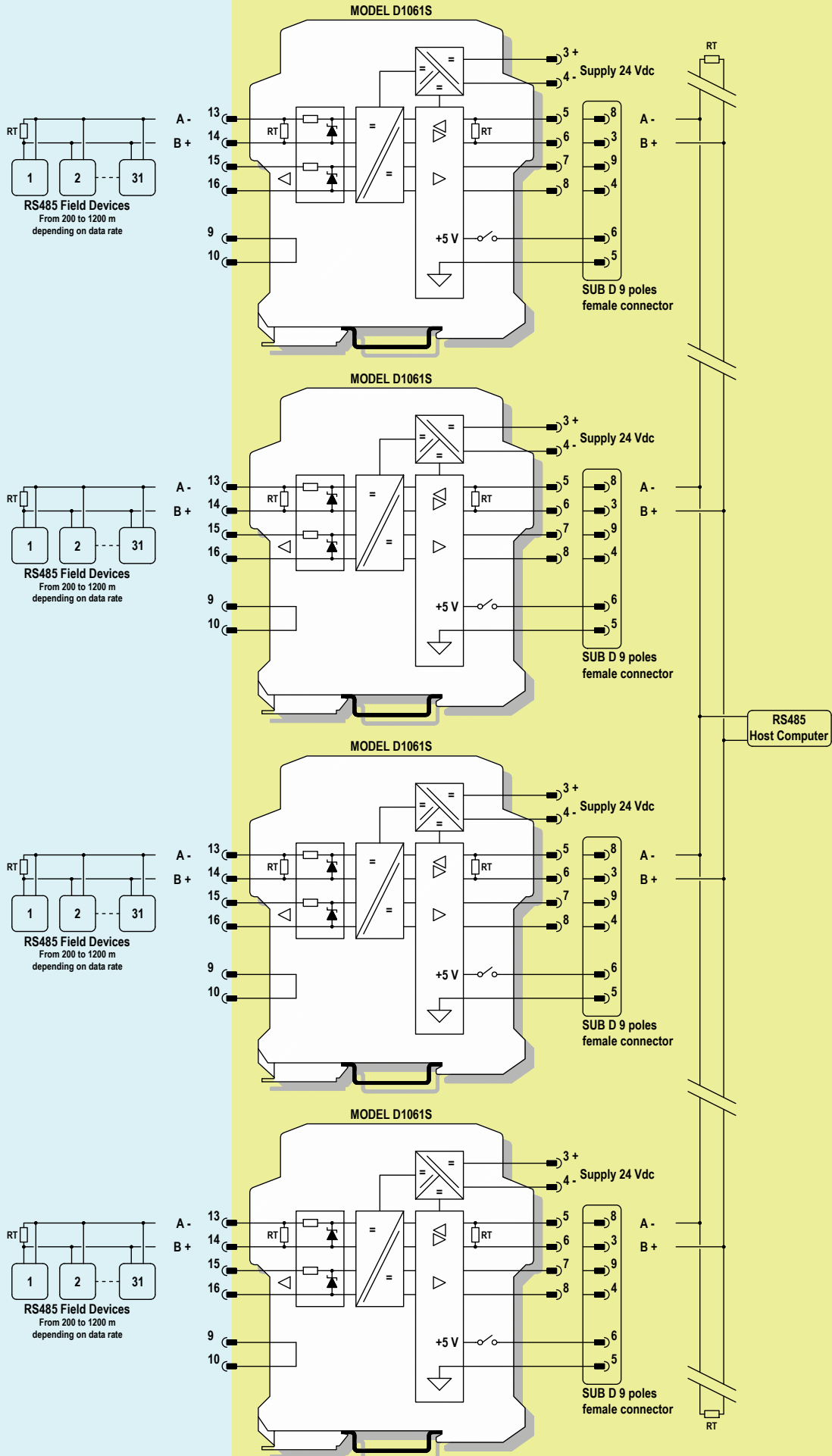

Warning

D1061 is an isolated Intrinsically Safe Associated Apparatus installed into standard EN/IEC60715 TH 35 DIN-Rail located in Safe Area/ Non Hazardous Locations or Zone 2, Group IIC, Temperature Classification T4, Class I, Division 2, Groups A, B, C, D, Temperature Code T4 and Class I, Zone 2, Group IIC, IIB, IIA Temperature Code T4 Hazardous Area/Hazardous Locations (according to FM Class No. 3611, CSA-C22.2 No. 213-M1987, CSA-E60079-15) within the specified operating temperature limits Tamb -20 to +60 °C, and connected to equipment with a maximum limit for AC power supply Um of 250 Vrms.

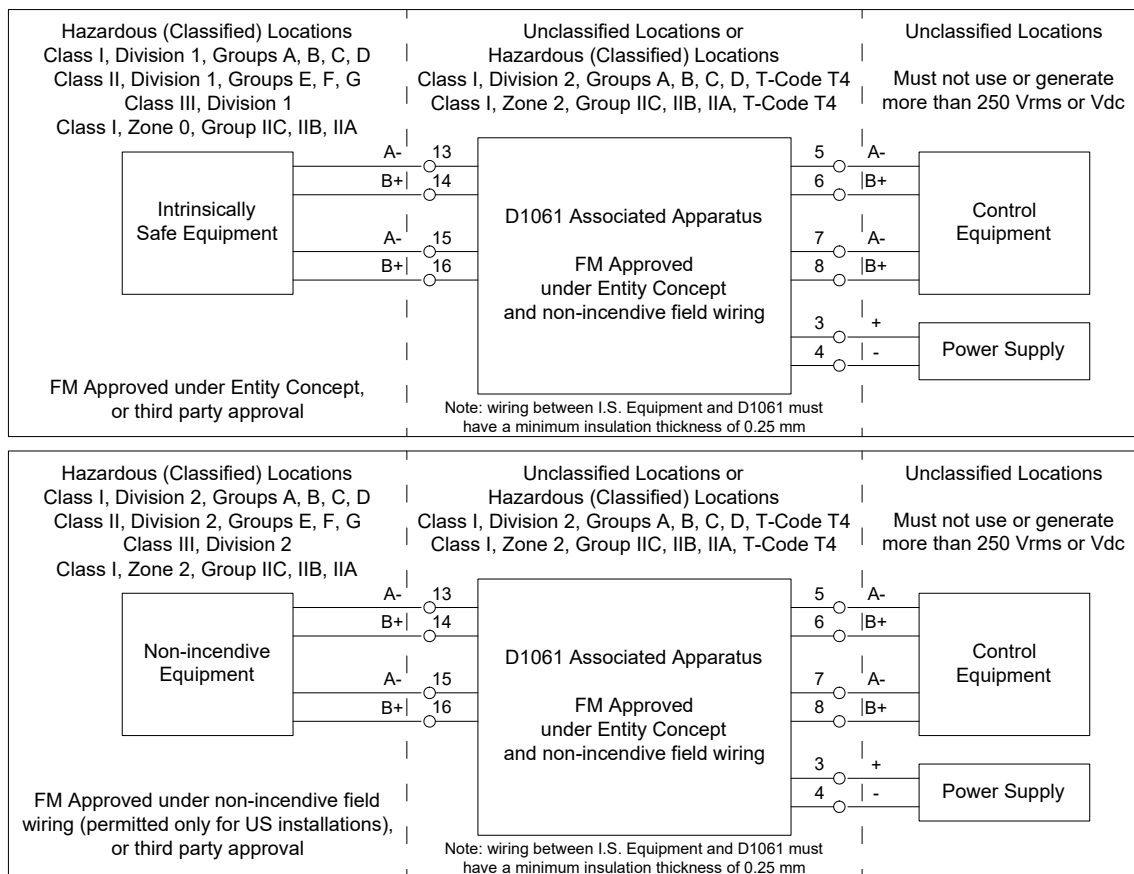

Non-incendive field wiring is not recognized by the Canadian Electrical Code, installation is permitted in the US only.

For installation of the unit in a Class I, Division 2 or Class I, Zone 2 location, the wiring between the control equipment and the D1061 associated apparatus shall be accomplished via conduit connections or another acceptable Division 2, Zone 2 wiring method according to the NEC and the CEC.

The wiring between the Intrinsically Safe Equipment located in Hazardous Area/Hazardous Locations and the D1061 Associated Apparatus must have a minimum insulation thickness of 0.25 mm.

Not to be connected to control equipment that uses or generates more than 250 Vrms or Vdc with respect to earth ground.

D1061 must be installed, operated and maintained only by qualified personnel, in accordance to the relevant national/international installation standards

(e.g. IEC/EN60079-14 Electrical apparatus for explosive gas atmospheres - Part 14: Electrical installations in hazardous areas (other than mines), BS 5345 Pt4, VDE 165, ANSI/ISA RP12.06.01 Installation of Intrinsically Safe System for Hazardous (Classified) Locations, National Electrical Code NEC ANSI/NFPA 70 Section 504 and 505,

Canadian Electrical Code CEC) following the established installation rules, particular care shall be given to segregation and clear identification of I.S. conductors from non I.S. ones. De-energize power source (turn off power supply voltage) before plug or unplug the terminal blocks when installed in Hazardous Area/Hazardous Locations or unless area is known to be nonhazardous.

Warning: substitution of components may impair Intrinsic Safety and suitability for Division 2, Zone 2.

Explosion Hazard: to prevent ignition of flammable or combustible atmospheres, disconnect power before servicing or unless area is known to be nonhazardous.

Failure to properly installation or use of the equipment may risk to damage the unit or severe personal injury.

The unit cannot be repaired by the end user and must be returned to the manufacturer or his authorized representative. Any unauthorized modification must be avoided.

Operation

D1061 fieldbus isolating repeater provides proper isolation and driving of an RS422/RS485 intrinsically safe line, located in Hazardous Area/Hazardous Location communicating with a RS422/RS485 line located in Safe Area/Non Hazardous Locations.

The unit also acts as a level translator adding the capability to connect an RS232 line located in Safe Area/Non Hazardous Locations and provides the proper line commutation without the need of additional control lines. The RS422 connection may be used on both sides instead of the RS485 2 wire connection.

Both the Profibus DP communication protocol and user-defined protocols are supported at baud rates from 1200 b/s to 1.5 MB/s for Profibus DP and from 1200 b/s up to 115200 b/s for RS232 protocols. The unit provides the line termination capability on both Hazardous and Safe side.

The receive/transmit switching of line drivers is managed by the internal logic so that, at the end of a communication frame, the transmitting driver is held active for a time equal to 9, 10, 11 or 12 bit units before releasing the line.

A "POWER ON" green led lits when input power is present, two yellow led monitor the transmission activities.

Installation

D1061 is a RS232/RS422/RS485 fieldbus isolating repeater housed in a plastic enclosure suitable for installation on EN/IEC60715 TH 35 DIN-Rail.

D1061 unit can be mounted with any orientation over the entire ambient temperature range, see section "Installation in Cabinet" and "Installation of Electronic Equipments in Cabinet" Instruction Manual D1000 series for detailed instructions.

Electrical connection of conductors up to 2.5 mm² are accommodated by polarized plug-in removable screw terminal blocks which can be plugged in/out into a powered unit without suffering or causing any damage; for RS232, RS422 and RS485 serial line connection in Safe Area, a SUB D 9 poles female connector is also provided

(for Zone 2 or Division 2 installations check the area to be nonhazardous before servicing).

The wiring cables have to be proportionate in relation to the current and the length of the cable.

On the section "Function Diagram" and enclosure side a block diagram identifies all connections and configuration DIP switches.

Identify the function and location of each connection terminal using the wiring diagram on the corresponding section, as an example:

Connect 24 Vdc power supply positive at terminal "3" and negative at terminal "4".

Connect field serial line type RS485 or receiving section of RS422 in Hazardous Area at terminal "13" and "14" corresponding to A- and B+.

In addition when using RS422 serial line, connect transmitting section at terminal "15" and "16" corresponding to A- and B+.

Connect field serial line type RS485 or receiving section of RS422 in Safe Area at terminal "5" and "6" corresponding to A- and B+.

In addition when using RS422 serial line, connect transmitting section at terminal "7" and "8" corresponding to A- and B+.

Safe Area side connection are also available on SUB D 9 poles female connector.

Note: please pay attention to the serial cable used for Safe Area connection. The internal wiring of the cable must be straight.

Intrinsically Safe conductors must be identified and segregated from non I.S. and wired in accordance to the relevant national/international installation standards

(e.g. EN/IEC60079-14 Electrical apparatus for explosive gas atmospheres - Part 14: Electrical installations in hazardous areas (other than mines), BS 5345 Pt4, VDE 165, ANSI/ISA RP12.06.01 Installation of Intrinsically Safe System for Hazardous (Classified) Locations, National Electrical Code NEC ANSI/NFPA 70 Section 504 and 505, Canadian Electrical Code CEC), make sure that conductors are well isolated from each other and do not produce any unintentional connection.

The wiring between the Intrinsically Safe Equipment located in Hazardous Area/Hazardous Locations and the D1061 Associated Apparatus must have a minimum insulation thickness of 0.25 mm.

The enclosure provides, according to EN/IEC 60529, an IP20 minimum degree of protection. The equipment shall only be used in an area of at least pollution degree 2, as defined in EN/IEC 60664-1. For hazardous location, the unit shall be installed in an enclosure that provides a minimum ingress protection of IP54 in accordance with EN/IEC 60079-0, that must have a door or cover accessible only by the use of a tool. Units must be protected against dirt, dust, extreme mechanical (e.g. vibration, impact and shock) and thermal stress, and casual contacts.

If enclosure needs to be cleaned use only a cloth lightly moistened by a mixture of detergent in water.

Electrostatic Hazard: to avoid electrostatic hazard, the enclosure of D1061 must be cleaned only with a damp or antistatic cloth.

Any penetration of cleaning liquid must be avoided to prevent damage to the unit. Any unauthorized card modification must be avoided.

According to EN61010, D1061 series must be connected to SELV or SELV-E supplies.

Start-up

Before powering the unit check that all wires are properly connected, particularly supply conductors and their polarity, input and output wires, also check that Intrinsically Safe conductors and cable trays are segregated (no direct contacts with other non I.S. conductors) and identified either by color coding, preferably blue, or by marking.

Check conductors for exposed wires that could touch each other causing dangerous unwanted shorts.

Turn on power, the "power on" green led must be lit, transmission led should reflect the communication line activity.

Configuration

Proper configuration is obtained using internal dip-switches. The user can configure the operating mode on both Hazardous and Safe side, as RS422, RS485, RS232 (RS232 is available only on Safe side), the baud rate of the communication from 1200 b/s to 1.5 Mb/s and the frame length of a byte, indicated as data size (7 or 8 bit), parity (none, even or odd) and number of stop bit (1 or 2). The connection of line terminating resistors can also be configured.

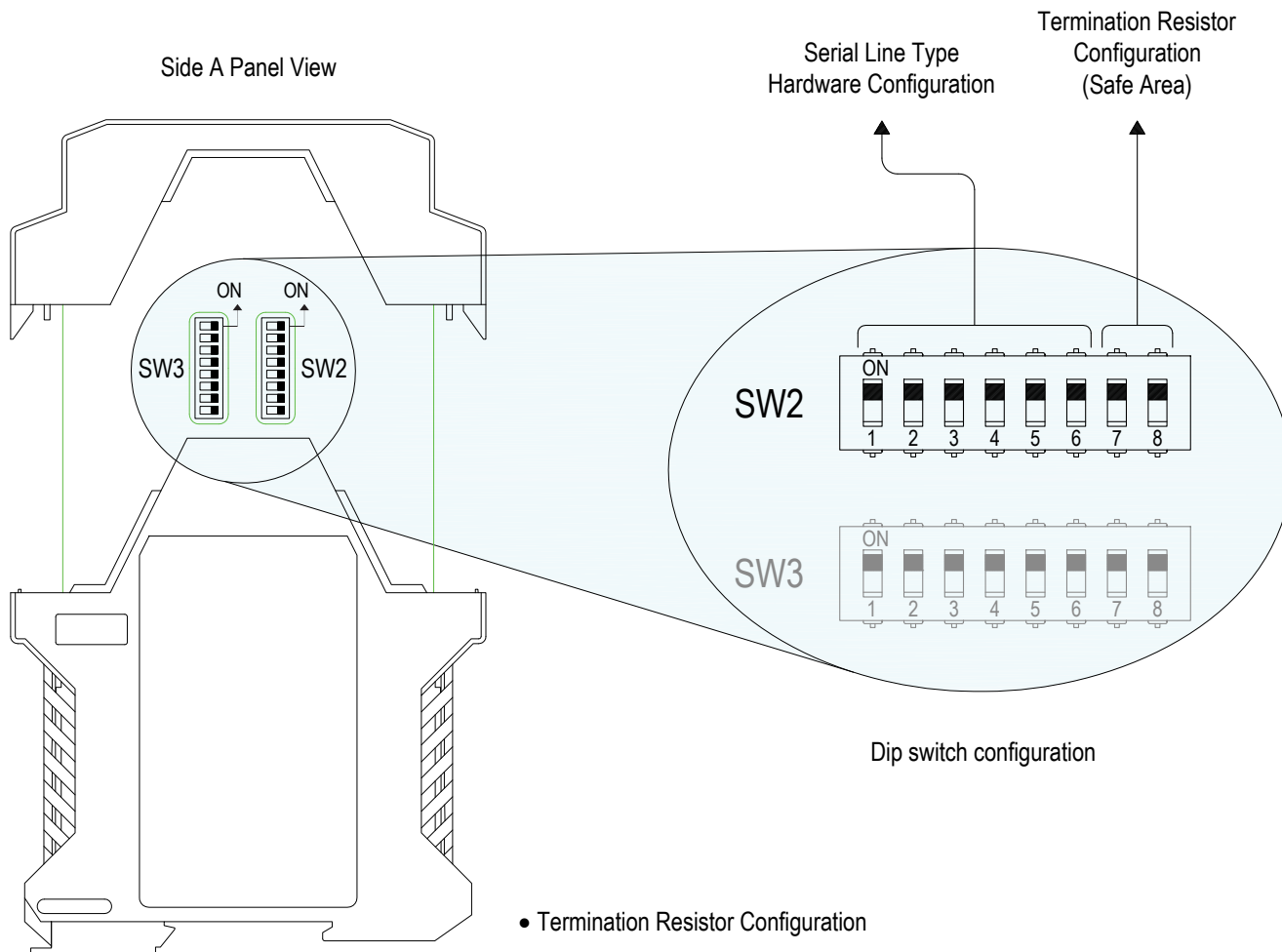

• Termination Resistor Configuration

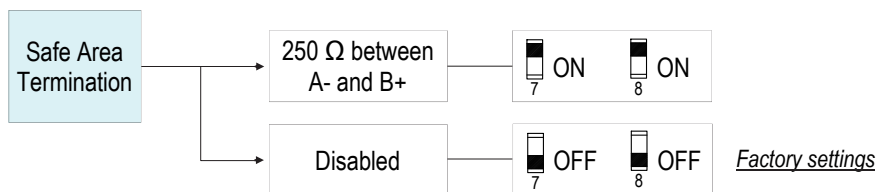

• Serial Line Type Hardware Configuration

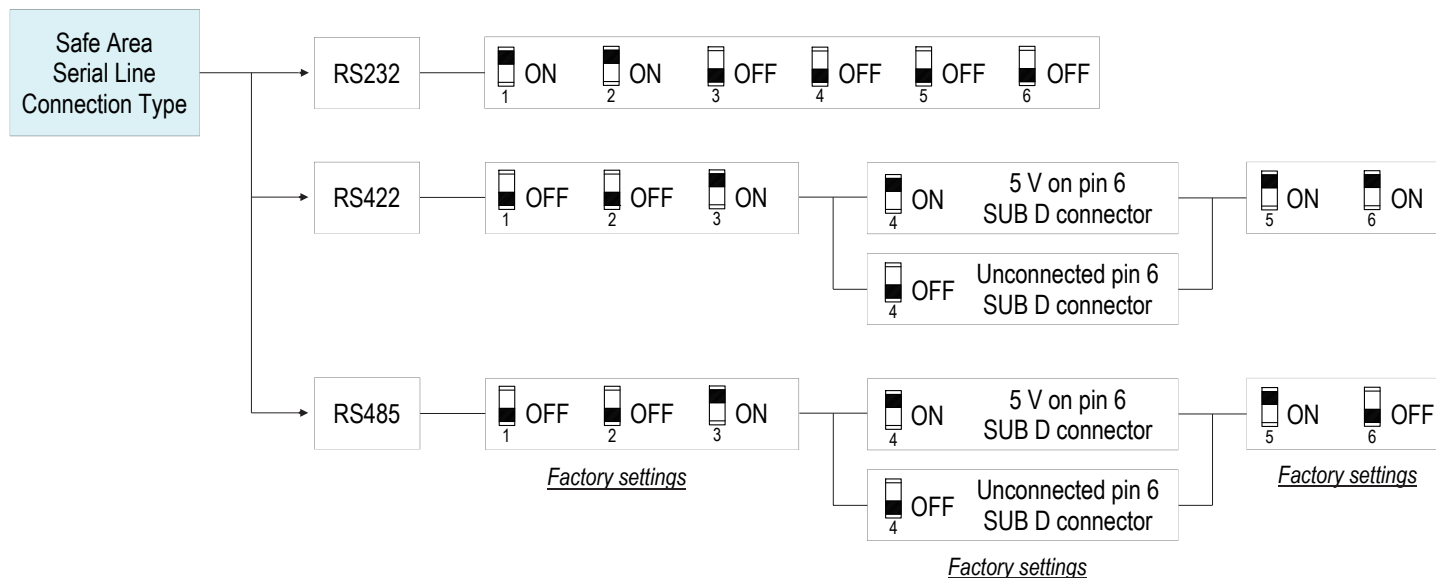

Side A Panel View

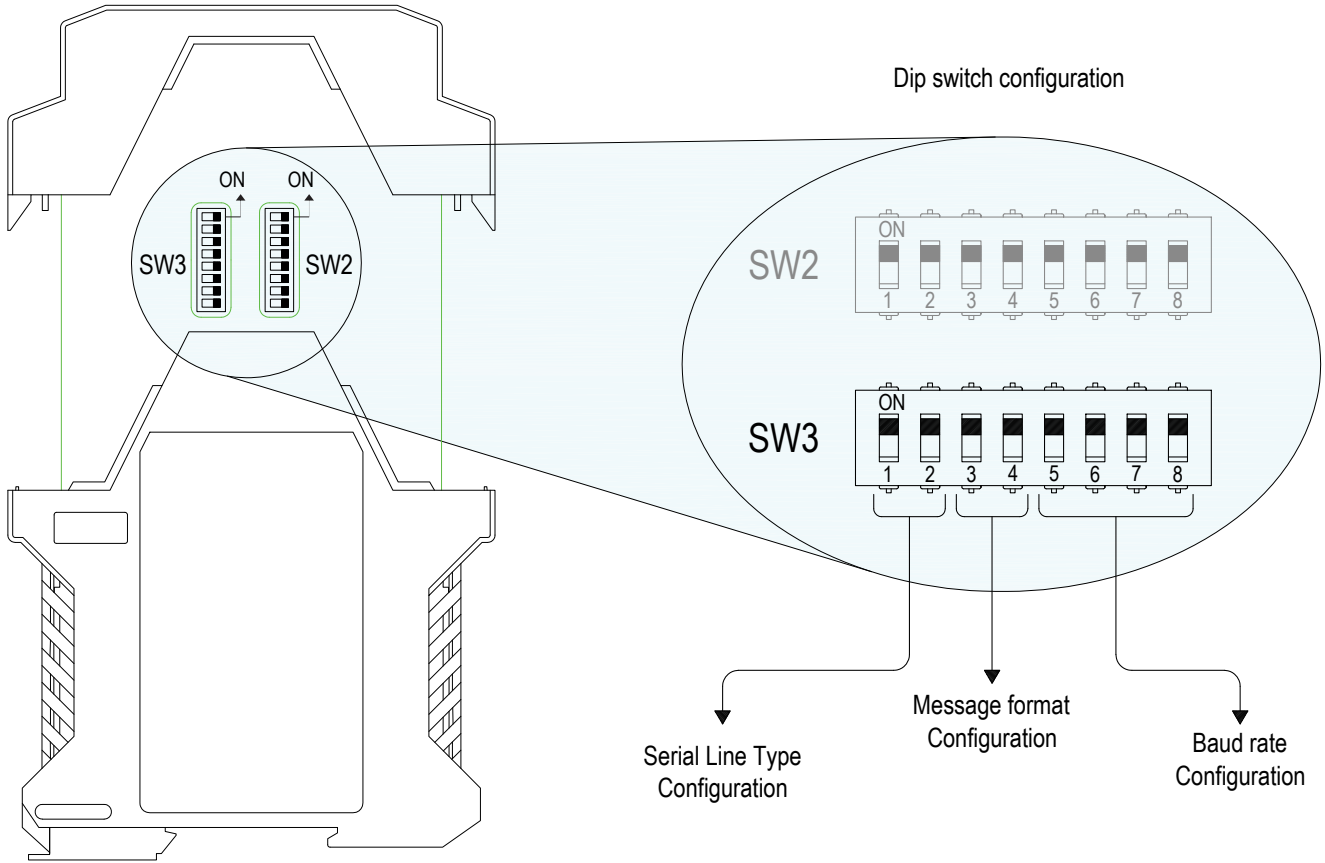

• Serial Line Type Configuration

Hazardous Area Serial Line	Safe Area Serial Line		
RS422	RS422 or RS232	<input type="checkbox"/> ON 1	<input type="checkbox"/> ON 2
RS422	RS485	<input type="checkbox"/> OFF 1	<input type="checkbox"/> ON 2
RS485	RS422 or RS232	<input type="checkbox"/> ON 1	<input type="checkbox"/> OFF 2
RS485	RS485	<input type="checkbox"/> OFF 1	<input type="checkbox"/> OFF 2





Factory settings

• Message format Configuration

Bit Frame Structure			Total # bit		
7 data bit,	no parity,	1 stop bit	9	<input type="checkbox"/> OFF 3	<input type="checkbox"/> OFF 4
7 data bit,	no parity,	2 stop bit	10	<input type="checkbox"/> ON 3	<input type="checkbox"/> OFF 4
7 data bit,	odd parity,	1 stop bit	10		
7 data bit,	even parity,	1 stop bit	10		
8 data bit,	no parity,	1 stop bit	10	<input type="checkbox"/> OFF 3	<input type="checkbox"/> ON 4
7 data bit,	odd parity,	2 stop bit	11		
7 data bit,	even parity,	2 stop bit	11		
8 data bit,	no parity,	2 stop bit	11		
8 data bit,	odd parity,	1 stop bit	11		
8 data bit,	even parity,	1 stop bit	11	<input type="checkbox"/> ON 3	<input type="checkbox"/> ON 4
8 data bit,	odd parity,	2 stop bit	12		
8 data bit,	even parity,	2 stop bit	12		

Factory settings

• Baud rate Configuration

Baud Rate	 5	 6	 7	 8
1.500.000	OFF	OFF	OFF	OFF
1.000.000	OFF	OFF	OFF	ON
750.000	OFF	OFF	ON	OFF
500.000	OFF	OFF	ON	ON
375.000	OFF	ON	OFF	OFF
187.500	OFF	ON	OFF	ON
93.750	OFF	ON	ON	OFF
115.200	OFF	ON	ON	ON
57.600	ON	OFF	OFF	OFF
38.400	ON	OFF	OFF	ON
19.200	ON	OFF	ON	OFF
14.400	ON	OFF	ON	ON
9.600	ON	ON	OFF	OFF
4.800	ON	ON	OFF	ON
2.400	ON	ON	ON	OFF
1.200	ON	ON	ON	ON

Factory settings

Side B Panel View

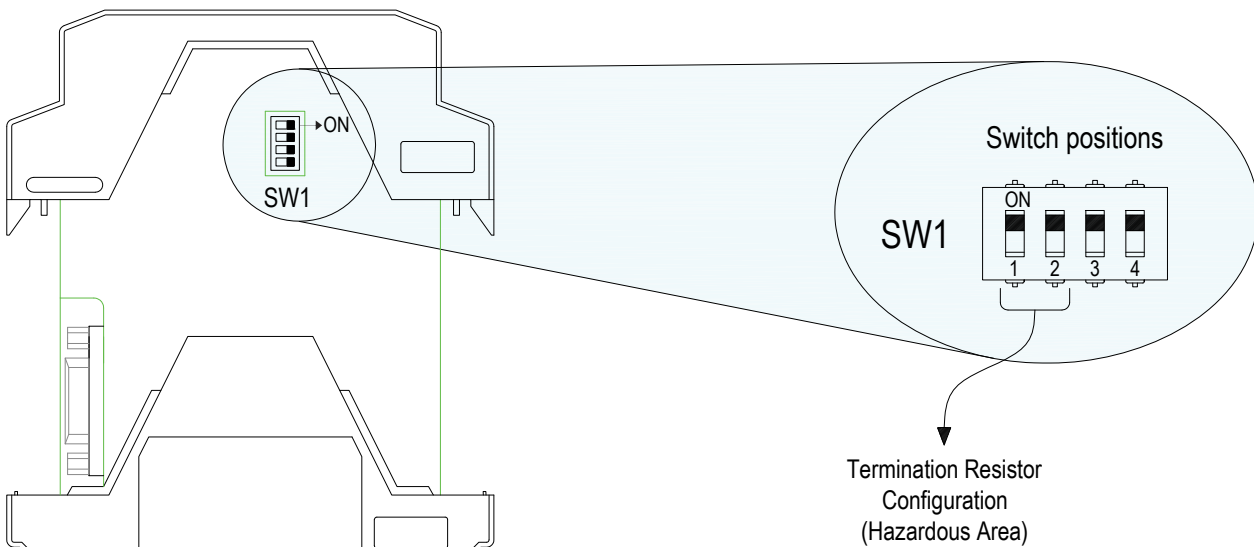

• Termination Resistor Configuration

