

D5048

I.S. SIL3 Loop-Powered Digital Output Driver
Model D5048S



INSTRUCTION AND SAFETY MANUAL

SUMMARY OF CONTENT

1. Characteristics	2
2. Technical data	2
3. Ordering information	4
3.1 Ordering codes	4
3.2 Accessories	4
4. OVERALL DIMENSIONS	4
5. Terminal block connections.....	4
5.1 Hazardous Side	4
5.2 Safe Side	5
6. Verification of intrinsically safe circuits	5
6.1 Intrinsically safe parameters table	5
7. Function diagram	6
8. Warning	6
9. Operation	7
10. Installation	7
11. Start-up.....	8
12. Configuration.....	8
12.1 D5048S.....	8
13. Functional Safety Manual and Application.....	9
13.1 Application of D5048S for NE load	9

1. CHARACTERISTICS

General Description:

The single channel Loop Powered Digital Output Isolator, D5048S, is suitable for driving solenoid valves, visual or audible alarms to alert a plant operator, or other process control devices in Hazardous Area from a driving signal in Safe Area. It can also be used as a controllable supply to power measuring or process control equipment. Its use is allowed in applications requiring up to SIL 3 level (according to IEC 61508:2010 Ed. 2) in safety related systems for high risk industries. The Safety PLC or DCS driving signal powers the field device through the D5048S, which provides isolation and is capable of monitoring the conditions of the line.

Short and open circuit diagnostic monitoring, dip-switch selectable and active when input power is present, provides LED indication and NC transistor output signaling. When fault is detected output is de-energized until normal condition is restored. Line short and open output circuit fault detection is also reflected on the PLC / DCS input circuit providing less than 10 mA consumption. In alternative, input impedance can be set to a value always lower than 2 k Ω . An override input, dip-switch selectable, is provided to permit a safety system to override the control signal. When enabled, a low input voltage always de-energizes the field device regardless of the input signal.

Three basic output circuits are selectable, with different safety parameters, to interface the majority of devices on the market. The selection among the three output characteristics is obtained by connecting the field device to a different terminal block.

Mounting on standard DIN-Rail, with or without Power Bus to provide fault signal, or on customized Termination Boards, in Safe Area / Non Hazardous Location or in Zone 2 / Class I, Division 2 or Class I, Zone 2.

Functional Safety Management certification:

G.M. International is certified by TUV to conform to IEC61508:2010 part 1 clauses 5-6 for safety related systems up to and included SIL3.

2. TECHNICAL DATA

Loop Input: loop powered control signal.

Loop Supply: 24 Vdc nom (20 to 30 Vdc) reverse polarity protected, 2 A time lag fuse internally protected. Supplies also diagnostic monitoring control circuit.

Current consumption @ 24 V: 65 mA with 45 mA output typical in normal operation, \leq 10 mA when fault circuit

enabled and fault condition detected.

Power dissipation: 1.1 W with 24 V supply, output energized at 45 mA nominal load.

Override Input: override control signal de-energizes output when enabled by dip-switch.

Override range: 24 Vdc nom (20 to 30 Vdc) to disable (field device controlled by input), 0 to 5 Vdc to de-energize field device, reverse polarity protected.

Current consumption @ 24 V: 15 mA max.

Isolation (Test Voltage): I.S. Out/In 2.5 KV; I.S. Out/Fault 2.5 KV; I.S. Out/Override 2.5 KV; In/Fault 500 V; In/Override 500 V; Fault/Override 500 V.

Output: 45 mA at 13.0 V (21.0 V no load, 174 Ω series resistance) at terminals 7-10 Out A.
45 mA at 10.2 V (21.0 V no load, 236 Ω series resistance) at terminals 8-10 Out B.
45 mA at 8.5 V (21.0 V no load, 275 Ω series resistance) at terminals 9-10 Out C.

Short circuit current: ≥ 50 mA (55 mA typical).

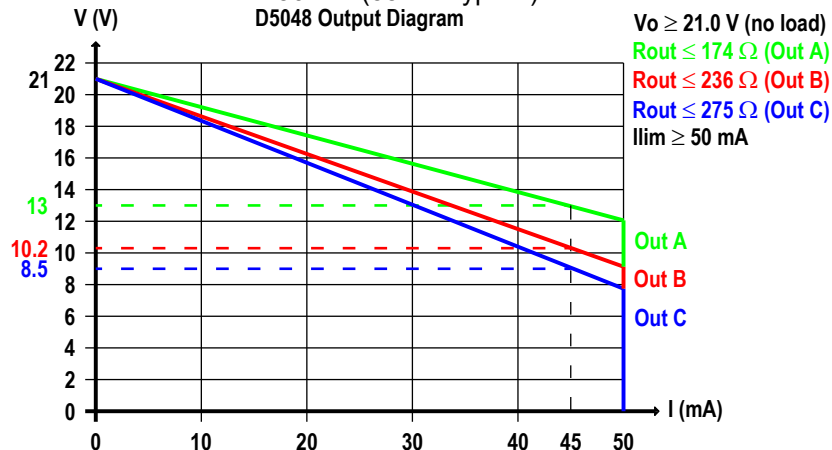

Response time: ≤ 75 ms.

Fault detection: field device and wiring open circuit or short circuit detection dip-switch selectable. When fault is detected output is de-energized until normal condition is restored.

Short output detection: load resistance ≤ 50 Ω (≈ 2 mA forcing to detect fault).

Open output detection: load resistance > 10 k Ω .

Fault signaling: voltage free NE SPST optocoupled open-collector transistor (output de-energized in fault condition and when input power not present).

To acquire the cumulative fault signal on the power bus, GM D5202S or D5203S module must be used. For details on their features and differences, see proper documentation - datasheet and instruction manual - for these models.

Open-collector rating: 100 mA at 35 Vdc (≤ 1.5 V voltage drop).

Leakage current: ≤ 50 μ A at 35 Vdc.

Input impedance: $I_{in} < 10$ mA when fault detected or $R_{in} < 2$ k Ω (dip-switch selectable).

Response time: ≤ 75 ms.

Compatibility:

CE mark compliant, conforms to Directive: 2014/34/EU ATEX, 2014/30/EU EMC, 2014/35/EU LVD, 2011/65/EU RoHS.

Environmental conditions:

Operating: temperature limits -40 to $+70$ $^{\circ}$ C, relative humidity 95 %, up to 55 $^{\circ}$ C.

Storage: temperature limits -45 to $+80$ $^{\circ}$ C.

Max altitude: 2000 m a.s.l.

Safety Description:

ATEX: II 3(1)G Ex ec [ia Ga] IIC T4 Gc, II (1)D [Ex ia Da] IIIC, I (M1) [Ex ia Ma] I

IECEx / INMETRO: Ex ec [ia Ga] IIC T4 Gc, [Ex ia Da] IIIC, [Ex ia Ma] I

UL: NI / I / 2 / ABCD / T4, AIS / I, II, III / 1 / ABCDEFG, AEx nA [ia Ga] IIC T4 Gc

C-UL: NI / I / 2 / ABCD / T4, AIS / I, II, III / 1 / ABCDEFG, Ex nA [ia Ga] IIC T4 Gc

FM: NI-AIS / I / 2 / ABCD / T4, AIS / I,II,III / 1 / ABCDEFG, I / 2 / AEx nA [ia] / IIC / T4

FMC: NI-AIS / I / 2 / ABCD / T4, AIS / I,II,III / 1 / ABCDEFG, I / 2 / Ex nA [ia] / IIC / T4

EAC-EX: 2Ex ec [ia Ga] IIC T4 Gc X; [Ex ia Da] IIIC X; [Ex ia Ma] I X

CCC: Ex ec [ia Ga] IIC T4 Gc; [Ex ia Ga] IIC; [Ex ia Da] IIIC

KCs: Ex nA [ia Ga] IIC T4 Gc

PESO: Ex ec [ia Ga] IIC T4 Gc

associated apparatus and non-sparking electrical equipment.

Uo/Voc = 24.8 V, Io/Isc = 147 mA, Po/Po = 907 mW at terminals 7-10 Out A.

Uo/Voc = 24.8 V, Io/Isc = 108 mA, Po/Po = 667 mW at terminals 8-10 Out B.

Uo/Voc = 24.8 V, Io/Isc = 93 mA, Po/Po = 571 mW at terminals 9-10 Out C.

Um = 250 Vrms, -40 °C ≤ Ta ≤ 70 °C.

Approvals:

BVS 10 ATEX E 113 X conforms to EN60079-0, EN60079-7, EN60079-11.

IECEX BVS 10.0072 X conforms to IEC60079-0, IEC60079-7, IEC60079-11.

INMETRO DNV 13.0109 X conforms to ABNT NBR IEC60079-0, ABNT NBR IEC60079-7, ABNT NBR IEC60079-11.

UL & C-UL E222308 conforms to UL913, UL 60079-0, UL60079-11, UL60079-15, ANSI/ISA 12.12.01 for UL and CSA-C22.2 No.157-92, CSA-E60079-0, CSA-E60079-11, CSA-C22.2 No. 213 and CSA-E60079-15 for C-UL.

FM 3046304 and FMC 3046304C conforms to Class 3600, 3610, 3611, 3810,

ANSI/ISA-60079-0, ANSI/ISA-60079-11, ANSI/ISA-60079-15, C22.2 No.142, C22.2 No.157, C22.2 No.213, C22.2 No. 60079-0, C22.2 No. 60079-11, C22.2 No. 60079-15.

EAЭC RU C-IT.AA87.B.01310/24 conforms to GOST 31610.0, GOST 31610.7, GOST 31610.11.

CCC n. 2020322316000978 conforms to GB/T 3836.1, GB/T 3836.3, GB/T 3834.4

TC21109 for TIIS approval.

KTL 17-KA4BO-0196X for KCs approval (for D5040S).

PESO P652307 conforms to IEC60079-0, IEC60079-7, IEC60079-11.

TÜV Certificate No. TUV IT 25 SIL 0633, SIL 3 conforms to IEC61508:2010 Ed.2.

SIL 3 Functional Safety TÜV Certificate conforms to IEC61508:2010 Ed.2, for Management of Functional Safety.

DNV Type Approval Certificate No. TAA00001U0 and KR No.MIL20769-EL002 Certificates for maritime applications.

Mounting: EN/IEC60715 TH 35 DIN-Rail with or without Power Bus or on customized Termination Board.

Weight: about 130 g.

Connection: by polarized plug-in disconnect screw terminal blocks to accommodate terminations up to 2.5 mm².

Location: installation in Safe Area/Non Hazardous Locations or Zone 2, Group IIC T4 or Class I, Division 2, Group A,B,C,D, T4 or Class I, Zone 2, Group IIC, T4.

Protection class: IP 20.

Dimensions: Width 12.5 mm, Depth 123 mm, Height 120 mm.

3. ORDERING INFORMATION

3.1 Ordering codes

D5048S: 1 channel

3.2 Accessories

Bus Connector JDFT049, Bus Mounting Kit OPT5096.

4. OVERALL DIMENSIONS

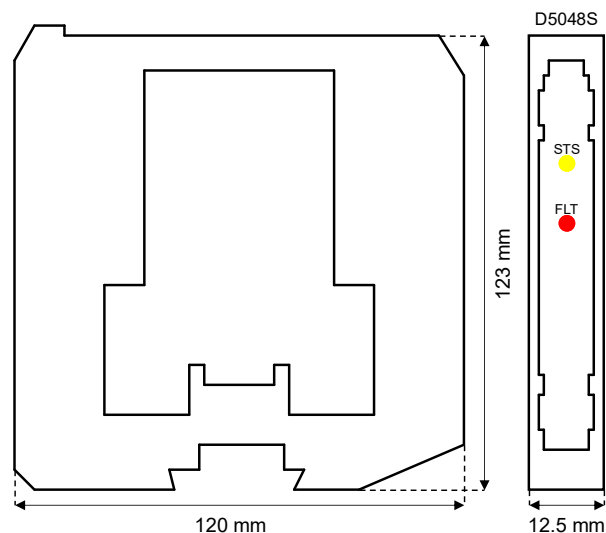

5. TERMINAL BLOCK CONNECTIONS

5.1 Hazardous Side

7: + Output A for Solenoid Valve

- 8: + Output B for Solenoid Valve
- 9: + Output C for Solenoid Valve
- 10: - Output for Solenoid Valve

5.2 Safe Side

- 1: + Control Input
- 2: - Control Input
- 3: + Transistor Fault Output
- 4: - Transistor Fault Output
- 5: + Input Override
- 6: - Input Override

6. VERIFICATION OF INTRINSICALLY SAFE CIRCUITS

In the system safety analysis, always check that field device maximum allowable voltage, current and power are not exceeded by the safety parameters of the associated apparatus connected to it. Check also that added connecting cable and field device capacitance and inductance do not exceed the limits given in the associated apparatus parameters for the effective gap group (Co, Lo, Lo/Ro).

Associated apparatus		Field device
Uo or Voc	≤	Ui or Vmax
Io or Isc	≤	Ii or Imax
Po or Pout	≤	Pi or Pmax
Co or Ca	≥	Ci + Ccable
Lo or La	≥	Li + Lcable
Lo/Ro	≥	Li/Ri and Lcable/Rcable

When used with separate powered intrinsically safe devices, check also that maximum allowable voltage, current and power of the associated apparatus are not exceeded by the safety parameters of the field device.

Associated apparatus		Field device
Ui or Vmax	≥	Uo or Voc
Ii or Imax	≥	Io or Isc
Pi or Pmax	≥	Po or Pout
Ci + Ccable	≤	Co or Ca
Li + Lcable	≤	Lo or La

For installations in which both the Ci and Li of the Intrinsically Safe apparatus exceed 1% of the Co or Ca and Lo or La parameters of the Associated Apparatus (excluding the cable), then 50% of Co or Ca and Lo or La parameters are applicable and shall not be exceeded (50% of the Co or Ca and Lo or La become the limits which must include the cable such that Ci device + C cable ≤ 50 % of Co or Ca and Li device + L cable ≤ 50 % of Lo or La). The reduced capacitance of the external circuit (including cable) shall not be greater than 1 μF for Groups I, IIA (or D), IIB (or C) and 600 nF for Group IIC (or A, B). If the cable parameters are unknown, the following value may be used: Capacitance 200 pF per meter (60 pF per foot), Inductance 1 μH per meter (0.20 μH per foot).

6.1 Intrinsically safe parameters table

	Group	Co or Ca [μF]	Lo or La [mH]	Lo/Ro [μH/Ω]
Term. 7-10 (Out A): Uo(Voc)=24.8 V; Io(Isc)=147 mA; Po(Pout)=907 mW Characteristic: linear	IIC (A, B)	0.113	1.65	39.2
	IIB (C)	0.86	6.63	156.8
	IIA (D)	3.05	13.27	313.6
	I	4.35	21.78	514.6
	IIIC (E, F, G)	0.86	6.63	156.8

	Group	Co or Ca [uF]	Lo or La [mH]	Lo/Ro [uH/Ω]
Term. 8-10 (Out B): Uo(Voc)=24.8 V; Io(Isc)=108 mA; Po(Pout)=667 mW Characteristic: linear	IIC (A, B)	0.113	3.07	53.3
	IIB (C)	0.86	12.3	213.5
	IIA (D)	3.05	24.6	427
	I	4.35	40.36	700.6
	IIIC (E, F, G)	0.86	12.3	213.5
Term. 9-10 (Out C): Uo(Voc)=24.8 V; Io(Isc)=93 mA; Po(Pout)=571 mW Characteristic: linear	IIC (A, B)	0.113	4.19	62.3
	IIB (C)	0.86	16.79	249.4
	IIA (D)	3.05	33.58	498.9
	I	4.35	55.09	818.5
	IIIC (E, F, G)	0.86	16.79	249.4

Isolation in accordance with EN/IEC 60079-11 clause 6.3.13 is provided between non-intrinsically safe circuits and intrinsically safe circuits.

IS parameters listed above comply with all applicable certifications for this product. For details regarding IS parameters of a specific certification, please refer to the certificate itself, that can be found on www.gminternational.com website.

7. FUNCTION DIAGRAM

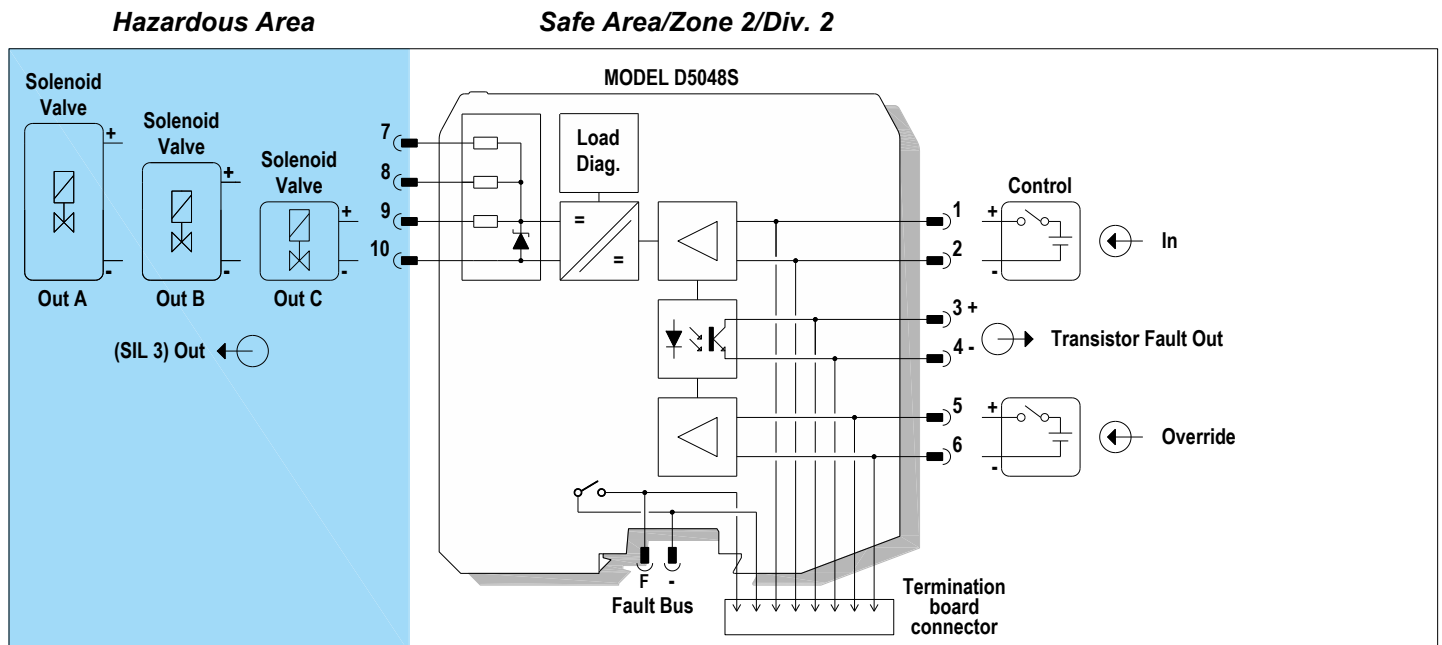

NOTE: Use only one output at a time (Out A or Out B or Out C).

8. WARNING

D5048 series is isolated Intrinsically Safe Associated Apparatus installed into standard EN/IEC60715 TH 35 DIN-Rail located in Safe Area or Zone 2, Group IIC, Temperature T4, Hazardous Area within the specified operating temperature limits Tamb -40 to +70 °C, and connected to equipment with a maximum limit for AC power supply Um of 250 Vrms.

Not to be connected to control equipment that uses or generates more than 250 Vrms or Vdc with respect to earth ground.

D5048 series must be installed, operated and maintained only by qualified personnel, in accordance to the relevant national/international installation standards (e.g. IEC/EN60079-14 Electrical apparatus for explosive gas atmospheres - Part 14: Electrical installations in hazardous areas (other than mines)), following the established installation rules, particular care shall be given to segregation and clear identification of I.S. conductors from non I.S. ones.

De-energize power source (turn off power supply voltage) before plug or unplug the terminal blocks when installed in Hazardous Area or unless area is known to be nonhazardous.

Warning: substitution of components may impair Intrinsic Safety and suitability for Zone 2.

Explosion Hazard: to prevent ignition of flammable or combustible atmospheres, disconnect power before servicing or unless area is known to be nonhazardous.

Failure to properly installation or use of the equipment may risk to damage the unit or severe personal injury.

The unit cannot be repaired by the end user and must be returned to the manufacturer or his authorized representative. Any unauthorized modification must be avoided.

9. OPERATION

The single channel Loop Powered Digital Output Isolator, D5048S, is suitable for driving solenoid valves, visual or audible alarms to alert a plant operator, or other process control devices in Hazardous Area from a driving signal in Safe Area. It can also be used as a controllable supply to power measuring or process control equipment. Its use is allowed in applications requiring up to SIL 3 level (according to IEC 61508) in safety related systems for high risk industries. The Safety PLC or DCS driving signal powers the field device through the D5048S, which provides isolation and is capable of monitoring the conditions of the line. Short and open circuit diagnostic monitoring, dip-switch selectable and active when input power is present, provides LED indication and NC transistor output signaling. When fault is detected output is de-energized until normal condition is restored. Line short and open output circuit fault detection is also reflected on the PLC / DCS input circuit providing less than 10 mA consumption. An override input, dip-switch selectable, is provided to permit a safety system to override the control signal. When enabled, a low input voltage always de-energizes the field device regardless of the input signal. Three basic output circuits are selectable, with different safety parameters, to interface the majority of devices on the market. The selection among the three output characteristics is obtained by connecting the field device to a different terminal block. Presence of output, as well as integrity or fault condition of device and connecting line are displayed by signaling LEDs (yellow for status, red for fault).

10. INSTALLATION

D5048 series is a Digital Output Driver housed in a plastic enclosure suitable for installation on EN/IEC60715 TH 35 DIN-Rail, with or without Power Bus or on customized Termination Board. D5048 series can be mounted with any orientation over the entire ambient temperature range.

Electrical connection are accommodated by polarized plug-in removable screw terminal blocks which can be plugged in/out into a powered unit without suffering or causing any damage (**for Zone 2 installations check the area to be nonhazardous before servicing**). Connect only one individual conductor per each clamping point, use conductors up to 2.5 mm² (13 AWG) and a torque value of 0.5-0.6 Nm. The wiring cables have to be proportionate in base to the current and the length of the cable.

In case of installation in zone 2, the connecting cables of non-intrinsically safe circuits must be safely routed in a cable duct or similar. The distance between the pluggable connection terminal and the cable duct should not exceed 500 mm cable length.

On the section "Function Diagram" and enclosure side a block diagram identifies all connections. Identify the function and location of each connection terminal using the wiring diagram on the corresponding section, as an example:

- Connect positive input at terminal "1" and negative input at "2".
- Connect positive transistor fault output at terminal "3" and negative at "4".
- Connect positive input override at terminal "5" and negative input at "6".
- Connect positive output A for solenoid valve at terminal "7" and negative at "10" or output B at terminal "8" and negative at "10" or output C at terminal "9" and negative at "10".

Intrinsically Safe conductors must be identified and segregated from non I.S. and wired in accordance to the relevant national/international installation standards (e.g. EN/IEC60079-14

Electrical apparatus for explosive gas atmospheres - Part 14: Electrical installations in hazardous areas (other than mines)), make sure that conductors are well isolated from each other

and do not produce any unintentional connection.

Connect SPST fault output transistors checking the load rating to be within the maximum rating (100 mA at 35 Vdc (≤ 1.5 V voltage drop)).

The enclosure provides, according to EN60529, an IP20 minimum degree of protection (or similar to NEMA Standard 250 type 1). The equipment shall only be used in an area of at least pollution degree 2, as defined in IEC 60664-1. When installed in EU Zone 2, the unit shall be installed in an enclosure that provides a minimum ingress protection of IP54 in accordance with IEC 60079-0. When installed in a Class I, Zone 2 Hazardous Location, the unit shall be mounted in a supplemental AEx or Ex enclosure that provides a degree of protection not less than IP54 in accordance with UL/CSA 60079-0. When installed in a Class I, Division 2 Hazardous Location, the unit shall be mounted in a supplemental enclosure that provides a degree of protection not less than IP54. The enclosure must have a door or cover accessible

only by the use of a tool. The end user is responsible to ensure that the operating temperature of the module is not exceeded in the end use application.

Units must be protected against dirt, dust, extreme mechanical (e.g. vibration, impact and shock) and thermal stress, and casual contacts. If enclosure needs to be cleaned use only a cloth lightly moistened by a mixture of detergent in water.

Electrostatic Hazard: to avoid electrostatic hazard, the enclosure of D5048 series must be cleaned only with a damp or antistatic cloth.

Any penetration of cleaning liquid must be avoided to prevent damage to the unit. Any unauthorized modification must be avoided. All circuits connected to D5048 series must comply with the overvoltage category II (or better) according to EN/IEC60664-1.

11. START-UP

Before powering the unit check that all wires are properly connected and verify their polarity, also check that Intrinsically Safe conductors and cable trays are segregated (no direct contacts with other non I.S. conductors) and identified either by color coding, preferably blue, or by marking. Check conductors for exposed wires that could touch each other causing dangerous unwanted shorts. Activate control input, the status led must be in accordance with condition of the corresponding input line.

12. CONFIGURATION

A configuration DIP switches are located on component side of pcb. These switches allows the configuration of override input and fault detection functions.

12.1 D5048S

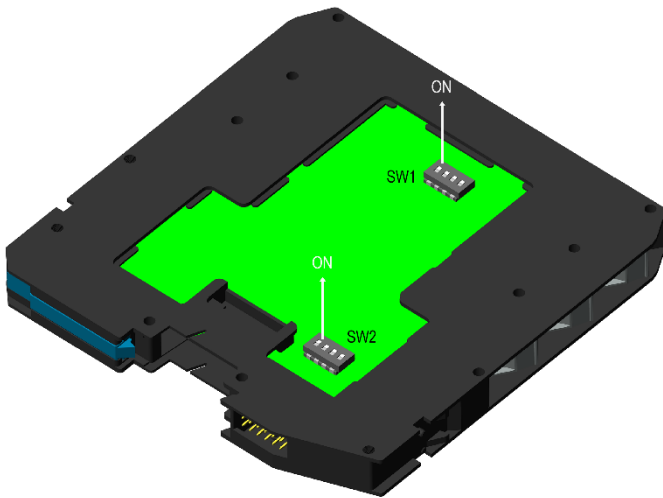

SW1 factory settings
All DIP-switches are ON

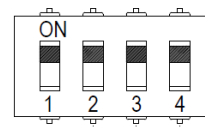

SW2 factory settings
DIP-switches 1-2-3 are ON and 4 is OFF

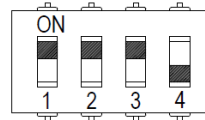

SW1 dip switch configuration

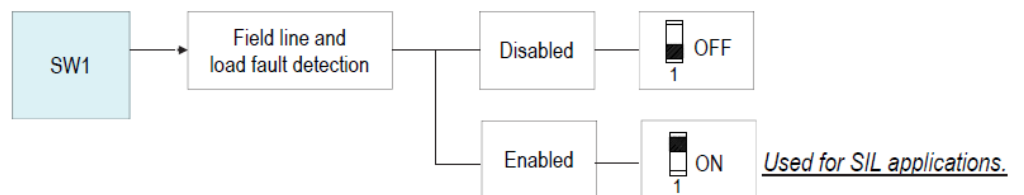
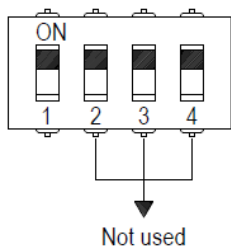

SW2 dip switch configuration

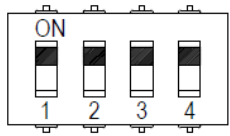

Not used

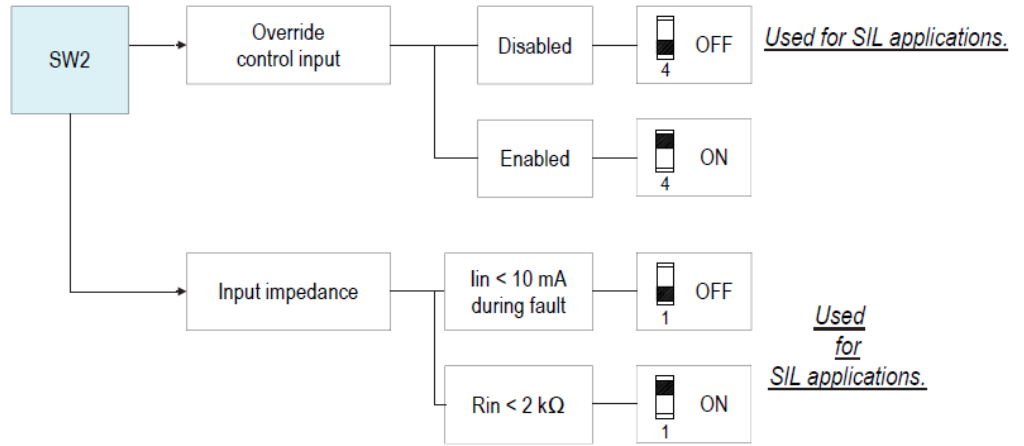

13. FUNCTIONAL SAFETY MANUAL AND APPLICATION

13.1 Application of D5048S for NE load

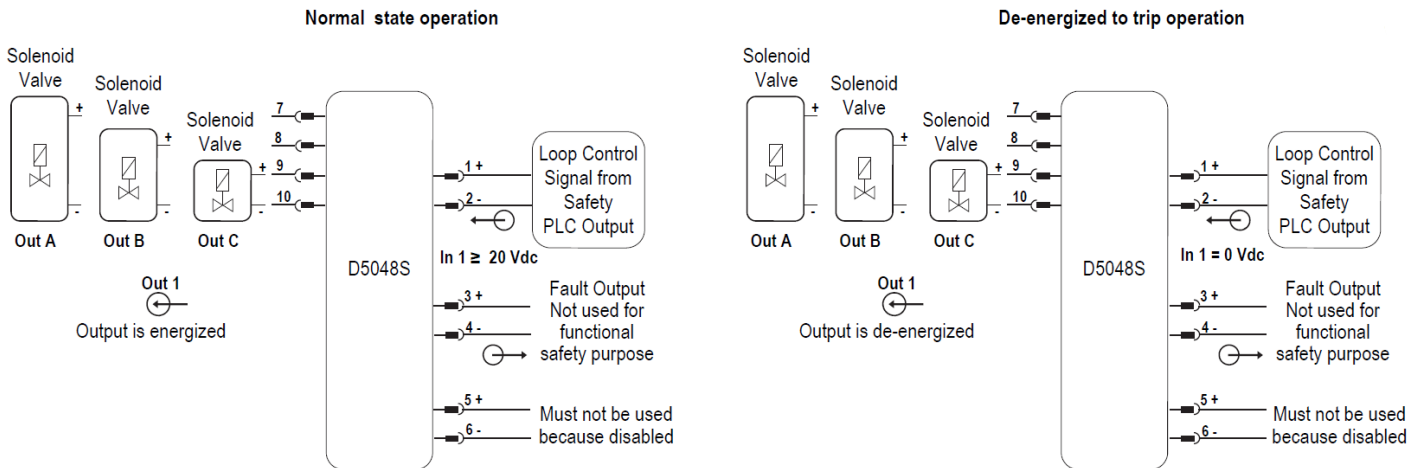

Description:

The D5048S is a single channel digital output drivers, loop powered for NE (Normally Energized) loads. The Safety PLC or DCS driving/control signals power the field devices through the single channel digital output driver D5048S (1 intrinsic safety channel, Loop Powered), which provides the electrical isolation between Input and Output. The presence of the input loop signal is also indicated by a yellow LED on the front panel.

In order to interface the majority of field devices available on the market, two basic output circuits with different safety parameters (outputs A, B and C) are provided for channel. The selection among the three output characteristics is obtained by connecting the field devices to a different couple of terminal blocks.

The field line and load fault detection is enabled, the override input is disabled, setting the internal DIP-switches in the following modes:

SW1 Dip-switch position	1	2	3	4	SW2 Dip-switch position	1	2	3	4
ON / OFF state	ON	-	-	-	ON / OFF state	-	-	-	OFF

Loop Control signals from Safety PLC Output is applied to Pins 1 - 2.

The Output NE loads are connected to Pins 7 - 10 or 8 - 10 or 9 - 10.

The following table describes the state (de-energized or energized) of each output when its control signals in the High or Low state:

Operation	Input Signal State Pins 1 - 2	Output State Pins 7-10 (Out A) or 8-10 (Out B) or 9-10 (Out C)
Normal	High (20 to 30 Vdc)	Energized
Trip	Low (0 Vdc)	De-energized (as safe state condition)

Safety Function and Failure behavior:

D5048S is considered to be operating in Low Demand mode, as a Type A module, having Hardware Fault Tolerance (HFT) = 0.

The failure behaviour of D5048S for NE loads is described by the following definitions:

- Fail-Safe State: it is defined as the output being de-energized;
- Fail Safe: failure mode that causes the module / (sub)system to go to the defined fail-safe state without a demand from the process;
- Fail Dangerous: failure mode that does not respond to a demand from the process (i.e. being unable to go to the defined fail-safe state), so that the output remains energized;
- Fail "No Effect": failure mode of a component that plays a part in implementing the safety function but that is neither a safe failure nor a dangerous failure. When calculating the SFF, this failure mode is not taken into account;
- Fail "Not part": failure mode of a component that is not part of the safety function but part of the circuit diagram and is listed for completeness. When calculating the SFF, this failure mode is not taken into account.

Since the loop powered module is directly supplied by the digital output of a Safety PLC, if the safety PLC imposes a shutdown state of this module, there is no additional power supply which can keep the D5048S output energized in case of an internal fault. Therefore, all internal faults have either "no effect" on the safety function or lead to the safe state, according to the Safety Function definitions.

Failure rate data: taken from Siemens Standard SN29500.

Failure rate table:

Failure category	Failure rates (FIT)
λ_{dd} = Total Dangerous Detected failures	0.00
λ_{du} = Total Dangerous Undetected failures	0.00
λ_{sd} = Total Safe Detected failures	0.00
λ_{su} = Total Safe Undetected failures	142.45
$\lambda_{tot\ safe}$ = Total Failure Rate (Safety Function) = $\lambda_{dd} + \lambda_{du} + \lambda_{sd} + \lambda_{su}$	142.45
MTBF (safety function, single channel) = $(1 / \lambda_{tot\ safe}) + MTTR$ (8 hours)	801 years
$\lambda_{no\ effect}$ = "No effect" failures	219.65
$\lambda_{not\ part}$ = "Not Part" failures	34.70
$\lambda_{tot\ device}$ = Total Failure Rate (Device) = $\lambda_{tot\ safe} + \lambda_{no\ effect} + \lambda_{not\ part}$	396.80
MTBF (device, single channel) = $(1 / \lambda_{tot\ device}) + MTTR$ (8 hours)	287 years
PFDavg (TI = 1 year) = $\frac{1}{2} \lambda_{du} * 8760\ h$	0.00E+00

Failure rates table according to IEC 61508:2010 Ed.2:

λ_{sd}	λ_{su}	λ_{dd}	λ_{du}	SFF
0.00 FIT	142.45 FIT	0.00 FIT	0.00 FIT	100%

Therefore, the D5048S module have SIL 3 level for lifetime of 20 years.

Systematic capability is SIL 3.

Since no dangerous undetected failures have been noted during the FMEDA analysis, there is no need to perform a proof test to reveal dangerous faults which cannot be otherwise detected.