

# 5700

SIL 3 HART® Multiplexer Modem suitable for Termination Board  
Models 5700, 5700-100



## INSTRUCTION MANUAL

## SUMMARY OF CONTENT

1. Characteristics .....	2
2. Technical data .....	3
3. Ordering information .....	4
3.1 Ordering codes .....	4
3.2 Accessories .....	4
4. OVERALL DIMENSIONS .....	4
5. Terminal block connections.....	4
5.1 Field Side.....	4
6. Function diagram .....	4
7. Loop Diagrams (IS Applications).....	5
8. Loop Diagrams (Non-IS Applications) .....	6
9. Mounting HART® Mux 5700 series module onto Termination Board.....	7
9.1 Mounting the HART® Mux 5700 series module onto a Termination Board .....	7
9.2 Removing the HART® Mux 5700 series module from Termination Board .....	7
10. Warning .....	8
11. Installation .....	8
12. System topology .....	8
13. LED indication .....	9
14. HART® Mux configuration .....	9
15. Start-up Sequence (Building).....	10
16. Scanning .....	10
17. Device Management Software .....	10
17.1 FDT/DTM Technology .....	10
17.1.1 HART® Mux 5700 FDT Setup.....	11
17.1.2 Device-Specific Window Access .....	12
17.1.3 HART® Mux 5700 Specific Windows.....	13
17.1.4 HART® Mux 5700 Parameter Windows.....	13
17.1.5 HART® Mux 5700 Diagnosis Windows.....	14
17.1.6 HART® Mux 5700 Boards Diagnosis Windows .....	15
17.1.7 HART® Mux 5700 Service Windows .....	16
17.1.8 HART® Mux 5700 Display Values Windows.....	17
17.1.9 HART® Mux 5700 Device Specific Status .....	18
17.1.10 HART® Mux 5700 Device-Specific Commands Specification .....	18
17.2 HART® OPC Server .....	28
17.3 AMS Device Manager™ / ARCOM Protocol .....	30

## 1. CHARACTERISTICS

### General Description:

The HART® Multiplexer Modem 5700 series interfaces up to 256 smart devices (transmitters, I/P, proportional valves, etc...) in a HART® Network. Each device can be fully identified, configured and monitored by a remote PC running an FDT-based software package (PACTware™, etc...) through a dedicated Device Type Manager (DTM), by HART® OPC Server, or by a specific asset management system through ARCOM protocol. Up to 63 Multiplexer Modem 5700 series (16128 loops) can be connected in multi-drop mode to the PC through the RS485 HART® Protocol, whose baudrate can be configured via software. The module is intended to be mounted on the following Termination Boards:

- TB-D5001-HRT-003, TBE-D5001-HRT-003: to be used with G.M. International AI/AO Termination Boards;
- TB-D5001-HRT-004, TBE-D5001-HRT-004: to be used with DIN-Rail mounted barriers/isolators or direct field connections, for 4-20mA loop signal and interfacing PLC AI cards with input 250 Ω typ.;
- TB-D5001-HRT-005, TBE-D5001-HRT-005: to be used with DIN-Rail mounted barriers/isolators or direct field connections, for 1-5V loop signal;

- TB-D5001-HRT-006, TBE-D5001-HRT-006: to be used with DIN-Rail mounted barriers/isolators or direct field connections, for 4-20mA loop signal and interfacing PLC AI cards with input 100-150  $\Omega$  typ.;
- TB-D5001-HRT-007, TBE-D5001-HRT-007: to be used with DIN-Rail mounted barriers/isolators or direct field connections, for 4-20mA loop signal and interfacing PLC AI cards with input 0-50  $\Omega$  typ.

Termination board types can be combined to manage different interfaces at the same time, simply respecting maximum number of connected channels. In case of HART® OPC Server communication, boards with different number of channels cannot be mixed up. The HART® Multiplexer Modem 5700 series is SIL 3 certified as non-interfering with the signal loops. The module guarantees three-port (supply/interface/channels) isolation.

## 2. TECHNICAL DATA

### Supply:

24 Vdc nom (18 to 30 Vdc) reverse polarity protected, via Termination Board.

**Current consumption @ 24 V:** 20 mA @ 24 Vdc typical (modem only), 40 mA @ 24 Vdc in full topology (with maximum number of extension boards), typical.

**Power dissipation:** 0.5 W @ 24 Vdc typical (modem only), 1 W @ 24 Vdc in full topology (with maximum number of extension boards), typical.

### Isolation (Test Voltage):

**Field Interface / Supply:** 500 Vrms.

**Field Interface / Serial Interface:** 500 Vrms.

**Supply / Serial Interface:** 500 Vrms.

### Input:

**Number of channels:** 256.

**HART® field device revision:** 5 to 7.

### Serial Interface:

**Type:** RS-485 differential pair and grounding.

**Topology:** multi-drop, master/slave connection.

**Baudrate:** from 1200 to 115200 bps, software configurable.

**Address:** 0 - 62, software configurable.

### Compatibility:

CE mark compliant, conforms to Directives: 2014/34/EU ATEX, 2014/30/EU EMC, 2014/35/EU LVD, 2011/65/EU RoHS.

### Environmental conditions:

**Operating:** temperature limits – 40 to + 70 °C, relative humidity 95 %, up to 55 °C.

**Storage:** temperature limits – 45 to + 80 °C.

**Max altitude:** 2000 m a.s.l.

### Safety Description:

**ATEX:** II 3G Ex ec IIC T4 Gc

**IECEX :** Ex ec IIC T4 Gc

**UL:** NI / I / 2 / ABCD / T4

**C-UL:** NI / I / 2 / ABCD / T4

non-sparking electrical equipment.

### Approvals:

UL 20 ATEX 2492 X conforms to EN60079-0, EN60079-7.

IECEX ULD 20.0042X conforms to IEC60079-0, IEC60079-7.

UL & C-UL E519244 conforms to UL 61010-1, UL 61010-2-201, UL121201 for UL and CSA C22.2 No. 61010-1, CSA C22.2 No. 61010-2-201, CSA-C22.2 No. 213 for C-UL.

SIL 3 conforms to IEC61508:2010 Ed.2.

### Mounting:

on customized Termination Board.

**Weight:** about 100 g.

**Location:** installation in Safe Area/Non Hazardous Locations or installation in Zone 2, Group IIC T4 or Class I, Division 2, Group A,B,C,D, T4 (only on TBE-D5001-HRT-xxx).

**Protection class:** IP 20.

**Dimensions:** Width 12.5 mm, Depth 123 mm, Height 120 mm.

### 3. ORDERING INFORMATION

#### 3.1 Ordering codes

5700: supports PACTware™, HART® OPC Server, ABB Ability™, Endress+Hauser FieldCare™, etc., any software FDT/DTM compliant

5700-110: supports Emerson AMS™

#### 3.2 Accessories

Programmable USB serial line Kit PPC5092 + SWC5090.

### 4. OVERALL DIMENSIONS



### 5. TERMINAL BLOCK CONNECTIONS

#### 5.1 Field Side

7: Optional short with 8 for write protection

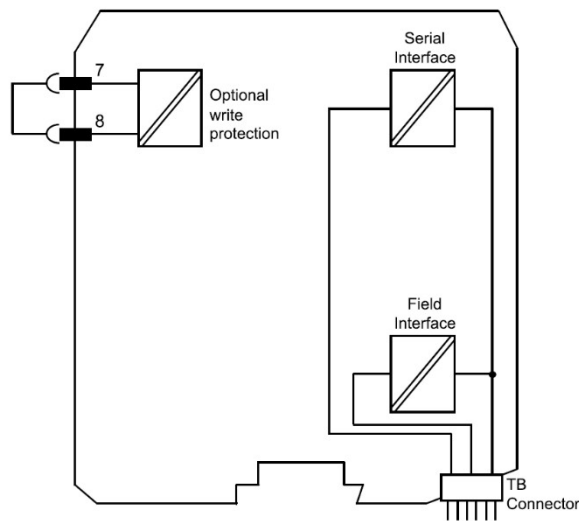
8: Optional short with 7 for write protection

### 6. FUNCTION DIAGRAM

*Field*

*Safe Area/Zone 2/Div. 2*

5700



## 7. LOOP DIAGRAMS (IS APPLICATIONS)

### Hazardous Area

### Safe Area/Zone 2/Div. 2

Fig. 1: Barriers on Termination Boards

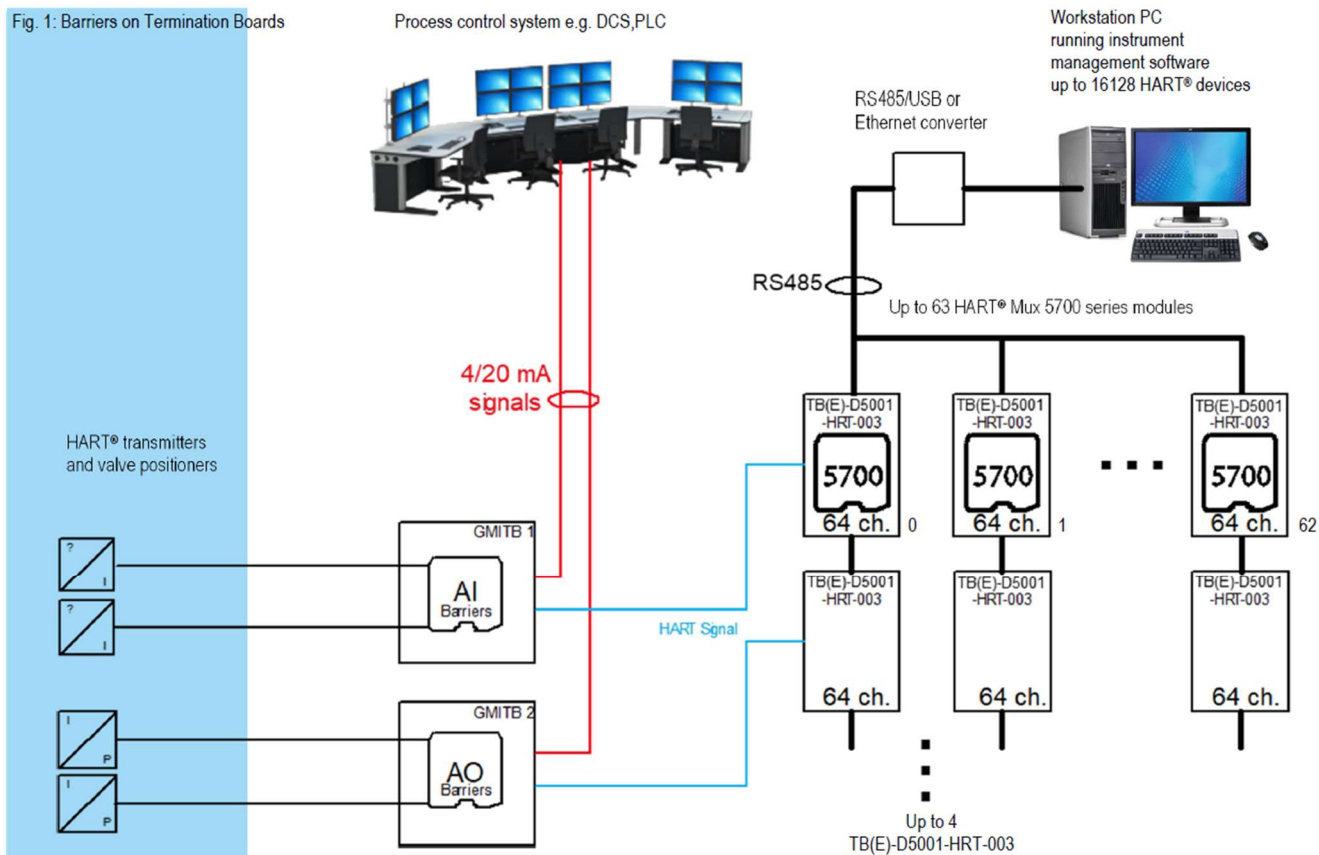
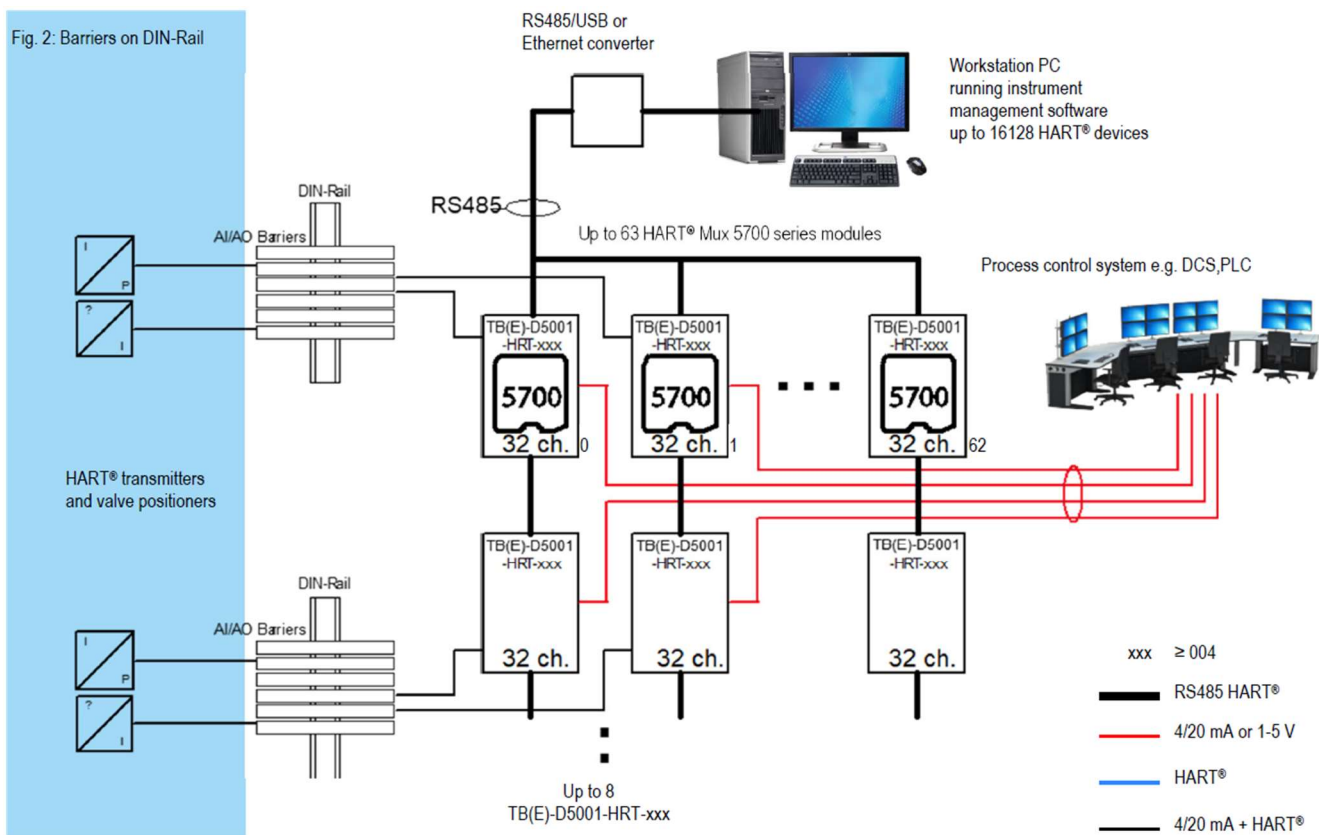


Fig. 2: Barriers on DIN-Rail



## 8. LOOP DIAGRAMS (NON-IS APPLICATIONS)

Fig. 3: Isolators on Termination Boards

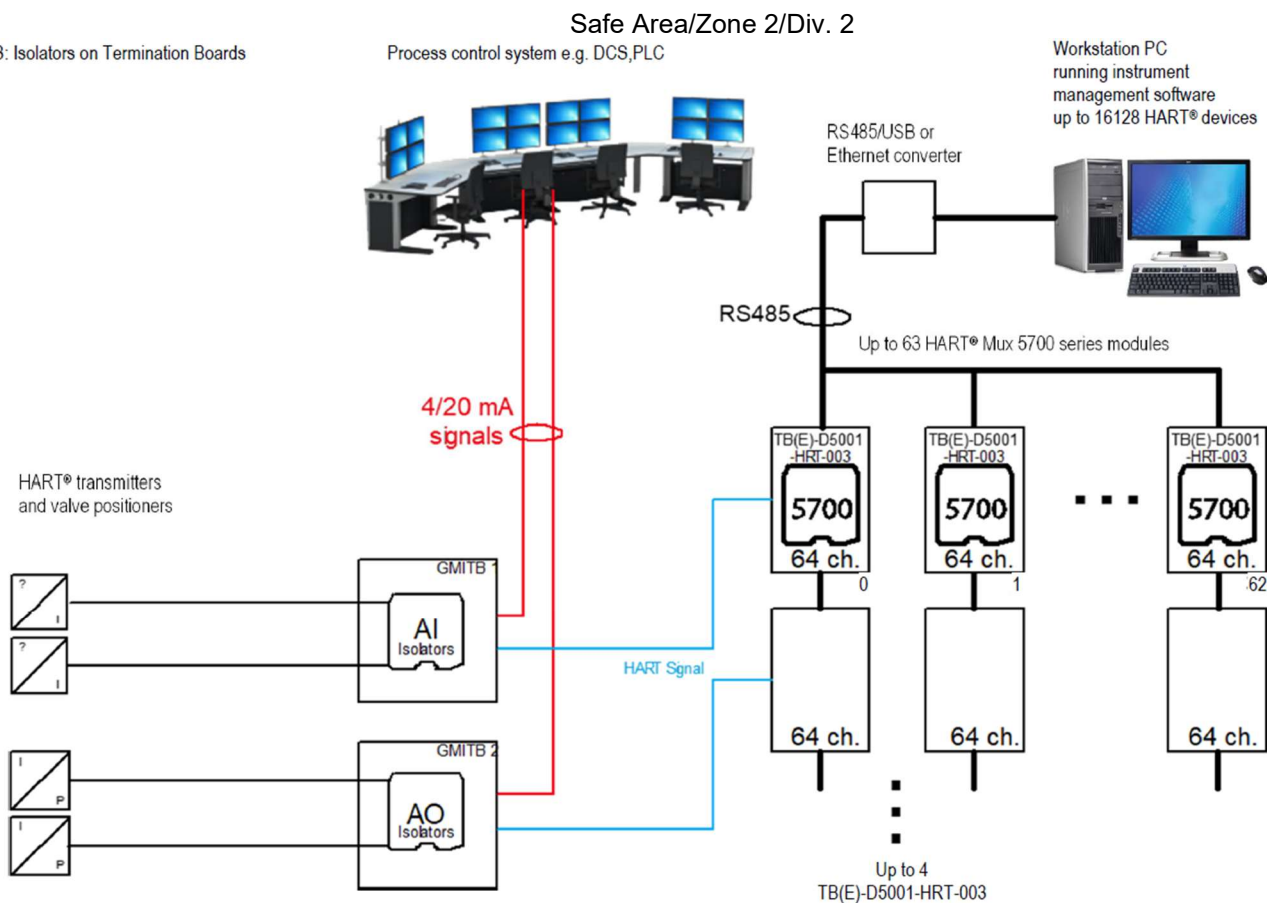
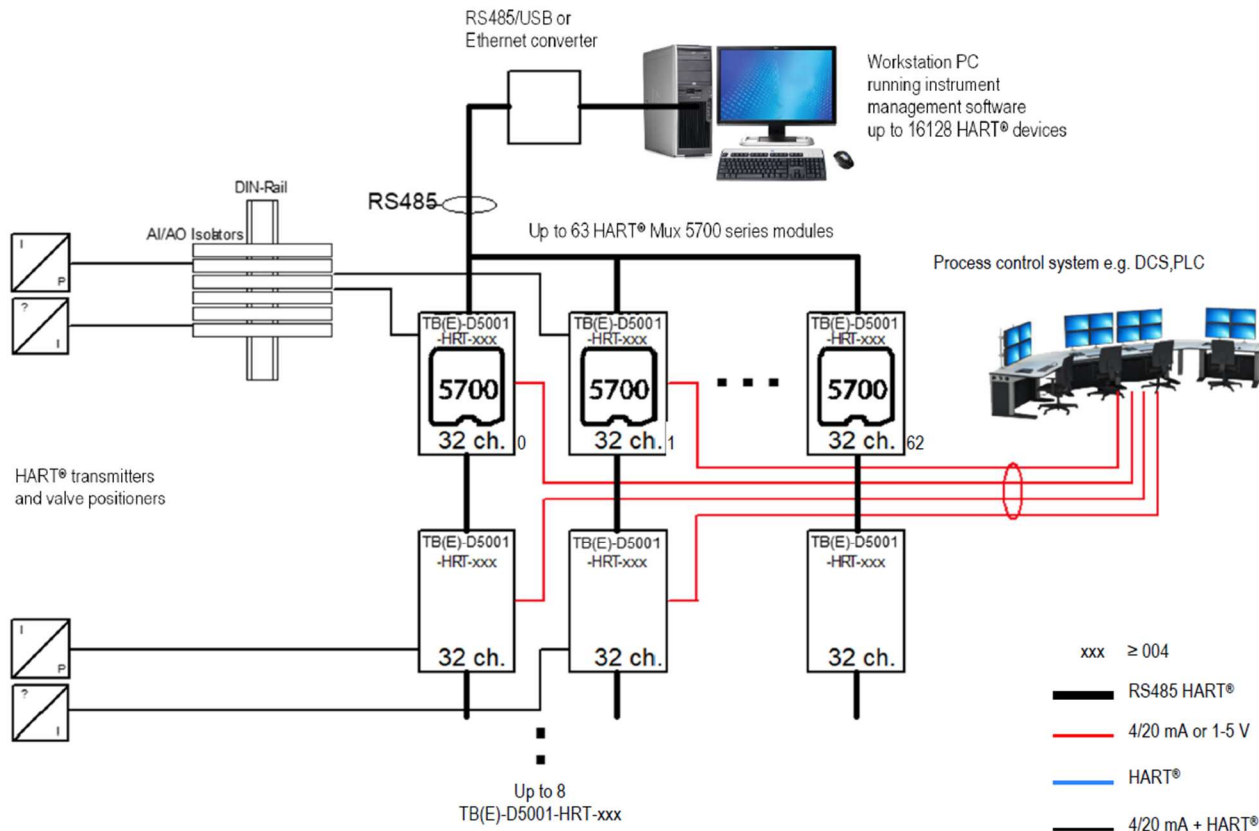


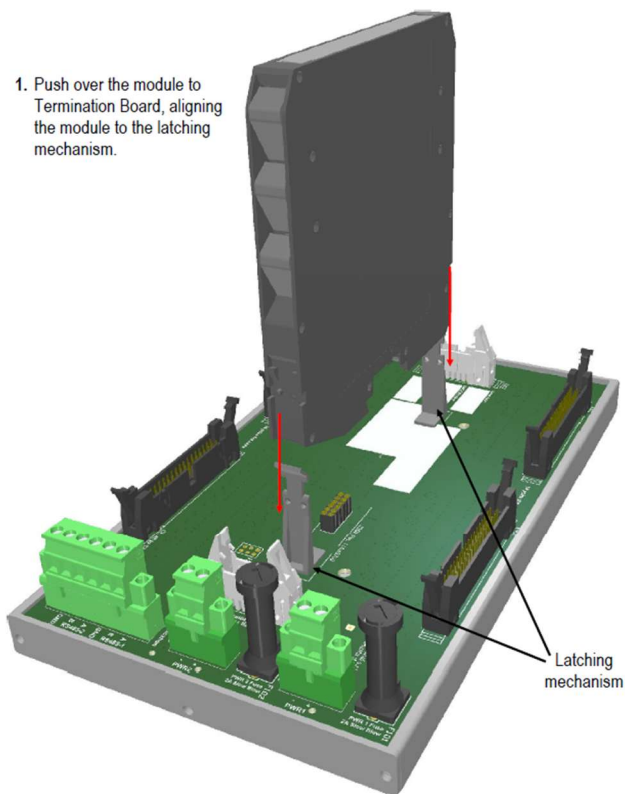
Fig. 4: Isolators on DIN-Rail or Direct Field Connections



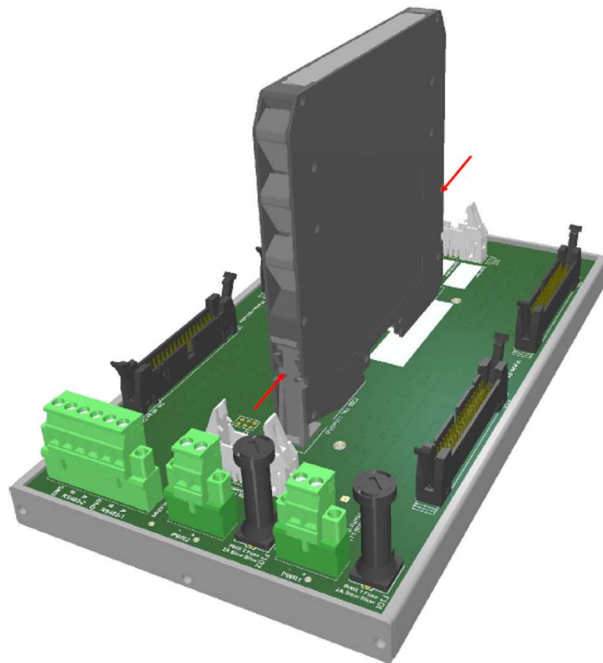
## 9. MOUNTING HART® MUX 5700 SERIES MODULE ONTO TERMINATION BOARD

### 9.1 Mounting the HART® Mux 5700 series module onto a Termination Board

1. Push over the module to Termination Board, aligning the module to the latching mechanism.

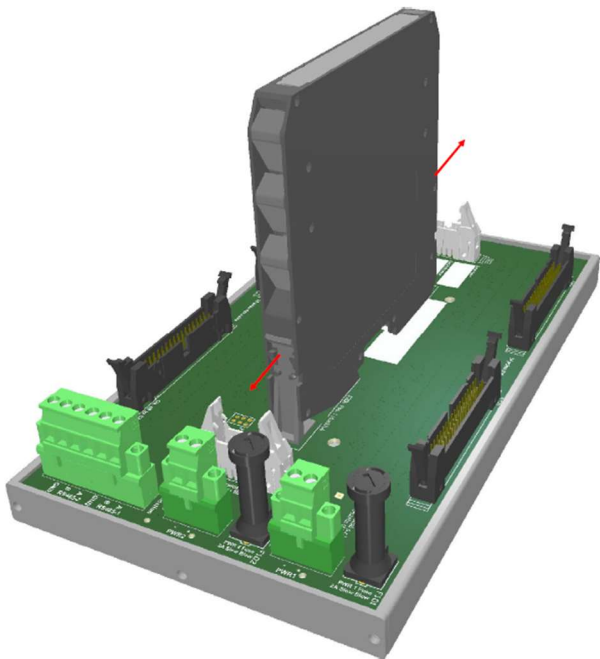


2. Press bottom up the latching mechanism.

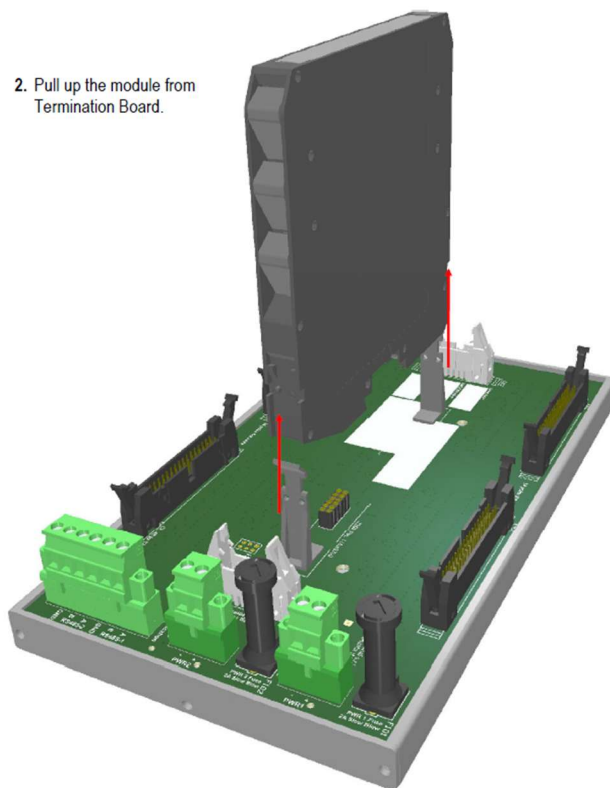


### 9.2 Removing the HART® Mux 5700 series module from Termination Board

1. Unclip the latching mechanism.



2. Pull up the module from Termination Board.



## 10. WARNING

5700 series is an isolated electrical apparatus installed on customized Termination Boards located in Safe Area or, only for TBE-D5001-HRT-xxx, in Zone 2, Group IIC, Temperature T4 or Class I, Division 2, Group A, B, C, D, T4 Hazardous Area within the specified operating temperature limits Tamb -40 to +70 °C.

5700 series must be installed, operated and maintained only by qualified personnel, in accordance to the relevant national/international installation standards (e.g. IEC/EN60079-14 Electrical apparatus for explosive gas atmospheres - Part 14: Electrical installations in hazardous areas (other than mines)), following the established installation rules.

De-energize power source (turn off power supply voltage) before plug or unplug the terminal blocks when installed in Hazardous Area or unless area is known to be nonhazardous.

Mini USB connector is intended for configuration purposes and shall not be used when installed in Hazardous Area, unless area is known to be nonhazardous.

**Warning: substitution of components may impair suitability for Zone 2/Division 2. Avertissement: la substitution des composants peut nuire à l'aptitude à la Zone 2/Div. 2.**

**Explosion Hazard: to prevent ignition of flammable atmospheres, disconnect power before servicing or unless area is known to be nonhazardous. Danger d'Explosion: pour éviter l'inflammation d'atmosphères inflammables, débrancher l'alimentation avant l'entretien ou à moins que région est connue pour être non dangereuse.**

Failure to properly installation or use of the equipment may risk to damage the unit or severe personal injury. The unit cannot be repaired by the end user and must be returned to the manufacturer or his authorized representative. Any unauthorized modification must be avoided.

## 11. INSTALLATION

5700 series is HART® multiplexer modem housed in a plastic enclosure suitable for installation on customized Termination Board. 5700 series is only to be mounted on Termination Boards models TB\*-D5001-HRT-xxx (xxx ≥ 003) or on other possible Termination Boards requiring 5700 series module.

5700 series can be mounted with any orientation over the entire ambient temperature range.

Electrical connection are accommodated by polarized plug-in removable screw terminal blocks which can be plugged in/out into a powered unit without suffering or causing any damage (**for Zone 2/Div.2 installations check the area to be nonhazardous before servicing**). Connect only one individual conductor per each clamping point, use conductors up to 2.5 mm<sup>2</sup> (13 AWG) and a torque value of 0.5-0.6 Nm. Use only cables that are suitable for a temperature of at least 85°C. The wiring cables have to be proportionate in base to the current and the length of the cable.

On the section "Function Diagram" and enclosure side a block diagram identifies all connections.

Installation and wiring must be in accordance to the relevant national/international installation standards (e.g. EN/IEC60079-14 Electrical apparatus for explosive gas atmospheres - Part 14: Electrical installations in hazardous areas (other than mines)), make sure that conductors are well isolated from each other and do not produce any unintentional connection.

The enclosure provides, according to EN60529, an IP20 minimum degree of protection (or similar to NEMA Standard 250 type 1). The equipment shall only be used in an area of at least pollution degree 2, as defined in IEC 60664-1. When installed in EU Zone 2, the unit shall be installed in an enclosure that provides a minimum ingress protection of IP54 in accordance with IEC 60079-0. When installed in a Class I, Division 2 Hazardous Location, the unit shall be mounted in a supplemental enclosure that provides a degree of protection not less than IP54. The enclosure must have a door or cover accessible only by the use of a tool. The end user is responsible to ensure that the operating temperature of the module is not exceeded in the end use application.

Units must be protected against dirt, dust, extreme mechanical (e.g. vibration, impact and shock) and thermal stress, and casual contacts. If enclosure needs to be cleaned use only a cloth lightly moistened by a mixture of detergent in water.

**Electrostatic Hazard: to avoid electrostatic hazard, the enclosure of 5700 must be cleaned only with a damp or antistatic cloth.**

Any penetration of cleaning liquid must be avoided to prevent damage to the unit. Any unauthorized card modification must be avoided.

## 12. SYSTEM TOPOLOGY

The HART® Mux 5700 series module can be used in five possible connection schemes, depending on the installation requirements and specific applications:

- 1) Direct connection to the field devices.
- 2) Connection through isolators installed on a DIN rail.
- 3) Connection through isolators installed on termination boards.

- 4) Connection through intrinsically safe barriers installed on a DIN rail.
- 5) Connection through intrinsically safe barriers installed on termination boards.

Each HART® Mux 5700 series module can manage a maximum of 256 channels, while the TB-D5001-HRT-003 (flat cables) and the other ones (terminal blocks) connect 64 and 32 channels respectively. This means that up to 4 TB-D5001-HRT-003 and 8 other type can be cascaded.

Power supply and RS-485 line shall be connected only to the termination board where HART® Mux 5700 series module is mounted (the first of the chain).

### 13. LED INDICATION

The front panel of the HART® Mux 5700 series module has three LEDs, which indicate the presence of the supply (POWER), the communication to the field (COMM.) and the specific operation (OPER.) carried out by the multiplexer. An exhaustive explanation is given in Table 1:

Operation LED (OPER.)	Field LED (COMM.)	Power LED (POWER)	Condition
OFF	OFF	OFF	No power supply
OFF	OFF	Green slow flashing	USB configuration
OFF	OFF	Green fast flashing	Initial start-up
Yellow slow flashing	Yellow intermittent flashing	Green	Building
OFF	OFF	Green	Power on, idle state
OFF	Yellow intermittent flashing	Green	Field ongoing communication
Yellow fast flashing	Yellow intermittent flashing	Green	Scanning
Red fast flashing	Yellow intermittent flashing	Green	Scanning, one or more loops disappeared
Red	Red	Red	Hardware fault

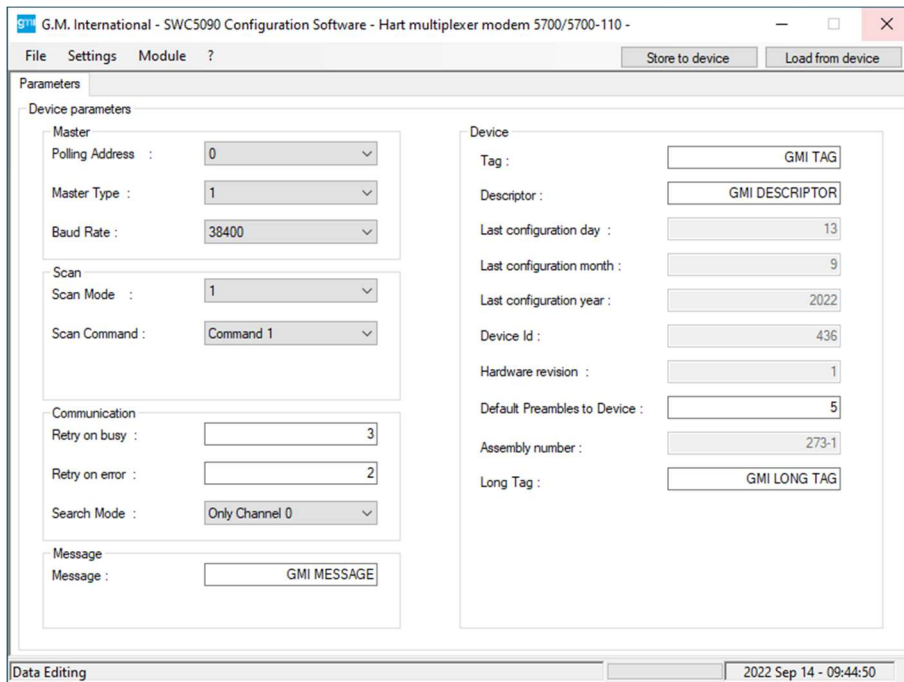
**Table 1: Meaning of the LEDs**

Three LEDs are available on the termination board. Two green LEDs are dedicated to the independent power supplies, while the yellow one indicates the status of the communication to the modem.

### 14. HART® MUX CONFIGURATION

Before using the HART® Mux 5700 series module, at least baudrate and polling address must be configured. To carry out the configuration, connect the mini-USB to the PPC5092 adapter without supplying the unit (the green power led flashes). Start the SWC5090 software (Figure 1). Choose the baudrate for the RS485 bus from the corresponding drop down menu. The polling address should be a value from 0 to 62, unique within the bus. When the configuration is done, save the information to the device by pressing the “Store to device” button, remove the mini-USB and mount the HART® Mux 5700 series module on the termination board.

For more information, please refer to SWC5090 software instruction manual (ISM0154).



**Figure 1: SWC5090 configuration software**

## 15. START-UP SEQUENCE (BUILDING)

At start-up the HART® Mux 5700 runs a 10s self-test procedure, indicated by the fast flashing of the power (green) LED on the unit and the slow flashing of the Communication (yellow) LED on the termination board. Once this is over, the two LEDs stop flashing, hence indicating that the board has correctly been addressed by the HART® Mux 5700.

Then the Mux proceeds with the **building** operation, indicated by the slow flashing of the yellow operation LED: all the available channels are sequentially searched for smart devices to allow direct communication between the host and the field slaves. The duration of this phase depends on a few variables: the number of connected termination boards, the actual presence of connected devices, the number of configured retries on error, the configured search mode. The slow flashing of the yellow operation LED lasts until building is over.

## 16. SCANNING

The **scan** is a specific operation made available by the HART® Mux 5700 that allows the user to monitor all connected field devices continuously. A selectable HART® command (1, 2 or 3) can be used to scan the slaves. A fast flashing of the yellow operation LED indicates that the scan is active. If one or more devices disappear, the operation LED light turns red. The updated results of the scan operation are available in the Diagnosis, Boards Diagnosis and Display Values Window (see following sections) of the frame program.

## 17. DEVICE MANAGEMENT SOFTWARE

The HART® Mux 5700 series can communicate to a wide range of Device Management Software:

- FDT/DTM technology based tools, such as PACTware™, Endress+Hauser FieldCare™, ValveLink™ DTM, etc.
- HART® OPC Server and tools based on it, such as ABB Ability™ Field Information Manager
- ARCOM protocol based tools, such as Emerson AMS Device Manager™, ValveLink™ SNAP-ON, etc.

The three different scenarios are presented in the following sections.

For FDT/DTM and OPC based tools use HART® Mux 5700.

For ARCOM protocol based tools use HART® Mux 5700-110.

### 17.1 FDT/DTM Technology

FDT (Field Device Tool) is an open standard for industrial automation that aims at controlling and monitoring networks of devices over many possible communication protocols, e.g. HART®.

FDT requires a frame program running on a Host PC that loads the DTM (Device Type Manager) libraries describing the behaviour and the parameters available for each field device.

PACTware™ (Process Automation Configuration Tool) is the recommended frame program, which can be downloaded from several vendors, together with the HART® Communication DTM (HART® protocol driver).

In order to communicate with the hardware, an USB/RS485 converter should be connected to the USB port of the Host. The DTM of the HART® Mux 5700 is available at the GM International website (<http://www.gminternationalsrl.com>). To install it, download the executable file and double click it; then, follow on screen instructions. The DTM of the field devices should be fetched from the single manufacturers web pages.

Eventually, the minimum required software tools, to be able to operate the HART® network, are the following:

- PACTware™ (4.1 or 5.0 recommended);
- HART® Communication DTM;
- DTM of HART® Mux 5700;
- DTM of connected field devices.

### 17.1.1 HART® Mux 5700 FDT Setup

In order to access the HART® Mux 5700 functionalities, it is necessary to setup the frame program, e.g. PACTware™ (Figure 2)

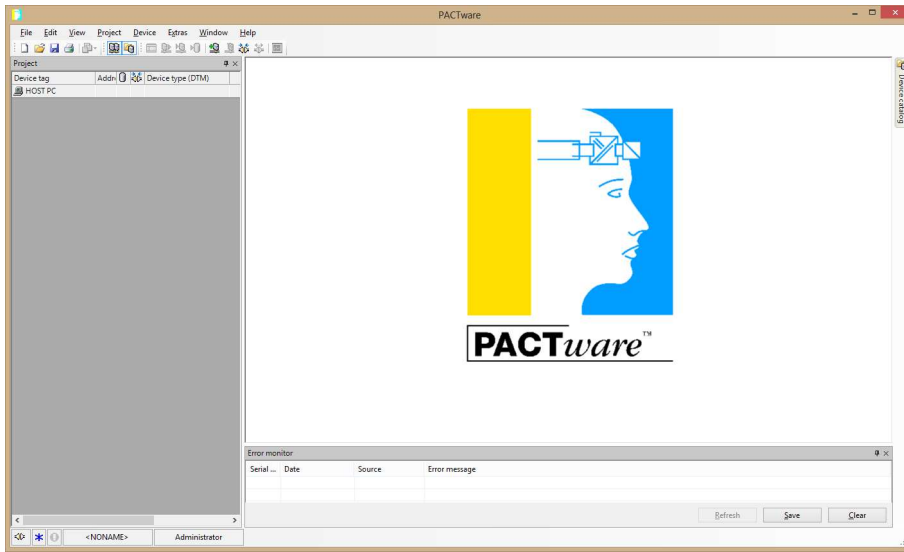
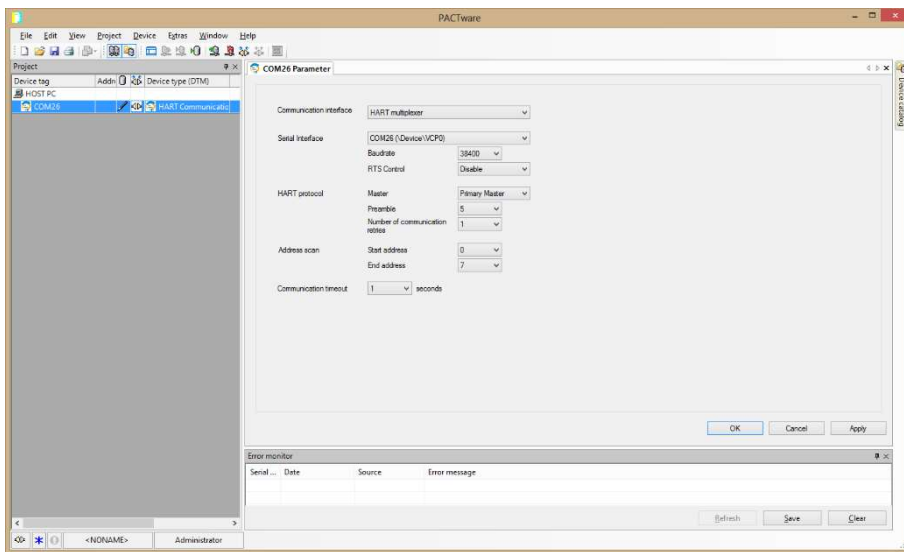


Figure 2: PACTware™

At the first start up after DTM installation a device catalog update is recommended.

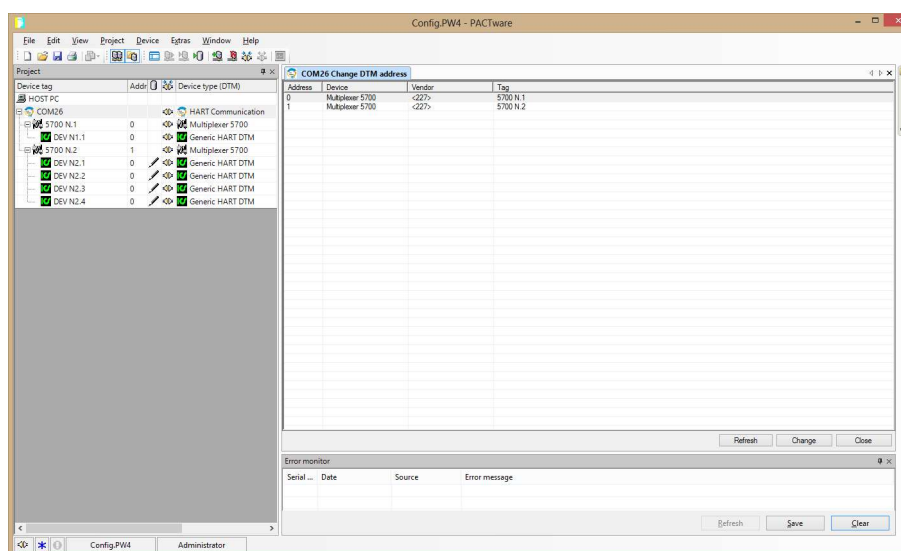
Add the HART® communication DTM to the Host in the Project window on the left (right click on HOST PC, select Add device and pick up the HART® Communication DTM). Choose “HART® multiplexer” as “Communication interface”. An example of configuration is given in Figure 3. Note that the baudrate should match the HART® Mux 5700 configuration. Note also that start and end address should include all the desired HART® Mux polling addresses.



**Figure 3: HART® Communication DTM configuration**

At this point two options are possible: if the user works **online** and all the hardware set up is in place, it is sufficient to connect the Communication DTM (right click on the Communication DTM and select Connect) and to run an automatic scan (right click on the Communication DTM and select Topology Scan). The connection tree is fully searched, HART® Muxes and field devices should automatically be located and the corresponding DTMs instantiated in the Project window. When more DTMs are possible for a single device, the Topology Scan window waits for the user to select the desired one.

Alternatively, the user can design his connection tree **offline**, by adding the devices in turn in the Project window. HART® Muxes should be directly appended to the Communication DTM, whereas the devices should be added to the specific HART® Mux they belong to, connected to the corresponding channel. Whichever solution the user prefers the final result should be similar to Figure 4:

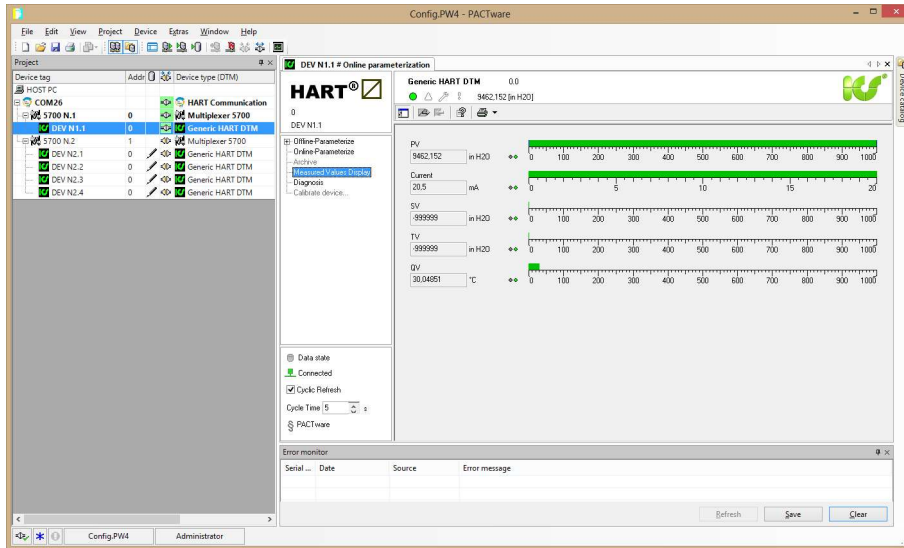


**Figure 4: Project example**

Note that each HART® Mux directly connected to the RS485 bus must have an individual address that matches the one specified in the Communication DTM. To change the addresses, right click on the Communication DTM, select **Change DTM address** and specify, in case, a new address by picking up the desired HART® Mux in the main window. Communication DTM must be in “disconnected” state to allow this operation.

### 17.1.2 Device-Specific Window Access

The main purpose of the HART® Mux 5700 DTM is to give the user the possibility of accessing the DTM of the connected devices. By double clicking on a device in the Project Window, the corresponding DTM opens and displays all the information and features that the manufacturer made available (Figure 5):



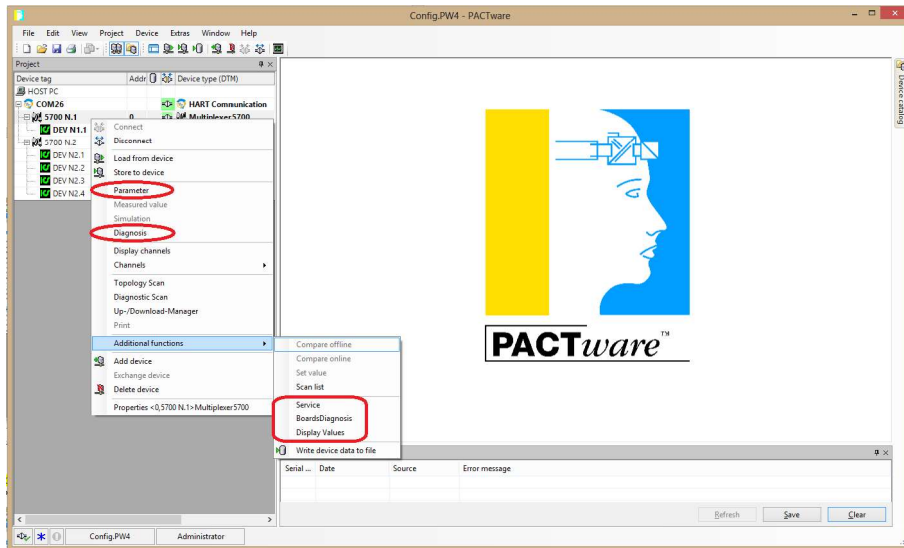
**Figure 5: Device-Specific Window Access**

### 17.1.3 HART® Mux 5700 Specific Windows

The HART® Mux 5700 DTM makes available different specific service windows (highlighted in Figure 6):

1. Parameter: multiplexer parameters.
2. Diagnosis: multiplexer cumulative diagnosis.
3. Additional Functions
  - a. Service: rebuild functions and other utilities.
  - b. BoardsDiagnosis: board channel distribution and loop monitor.
  - c. Display Values: dynamic variables for all loops.

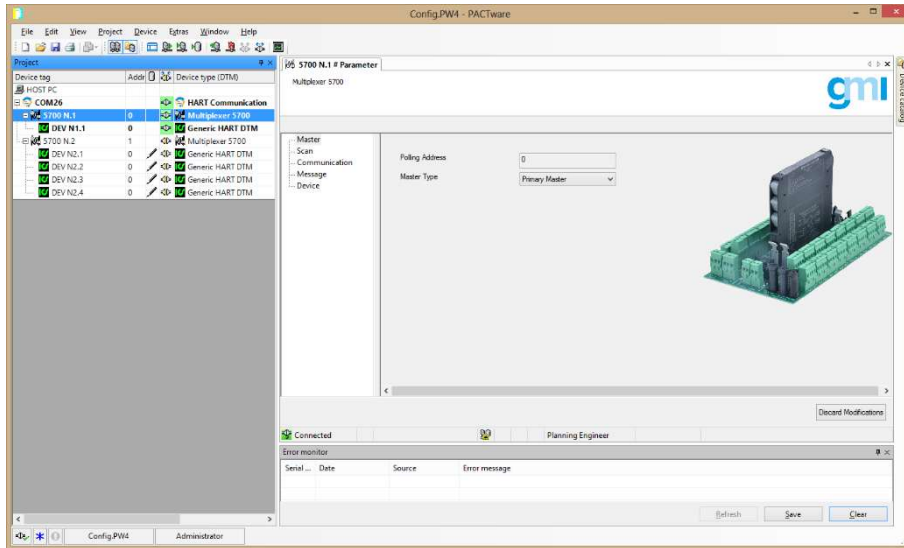
These windows are explained in more details in the following sections.



**Figure 6: HART® Mux 5700 specific windows**

### 17.1.4 HART® Mux 5700 Parameter Windows

To enter the Parameter Window (Figure 7), right click on the specific HART® Mux 5700 in the Project Window and select *Parameter* from the context menu.



**Figure 7: HART® Mux 5700 Parameter Window**

The parameters are organized in five sections. The asterisks distinguish the read-only data.

#### Master

Polling Address\*: short address for topology search (it must be set through the SWC5090)

Master Type: primary or secondary master type

#### Scan

Scan Mode: scan switch

Scan Command: HART® command used to scan the devices

#### Communication

Retries on Busy: number of retries when the device replies busy

Retries on Error: number of retries when the device replies with errors

Search Mode: building only polling address 0 (Channel 0) or from polling address 0 to 15 (All Channels) on each loop.

Note that the search mode from 0 to 15 can be much slower.

#### Message

Message: 32-character message string stored in the device

#### Device

Tag: 8-character tag string stored in the device

Descriptor: 16-character descriptor string stored in the device

Last configuration day\*: day of the last configuration (automatically written by the DTM)

Last configuration month\*: month of the last configuration (automatically written by the DTM)

Last configuration year\*: year of the last configuration (automatically written by the DTM)

Device Id: device serial number

Universal Command Revision\*: HART® revision supported by the DTM

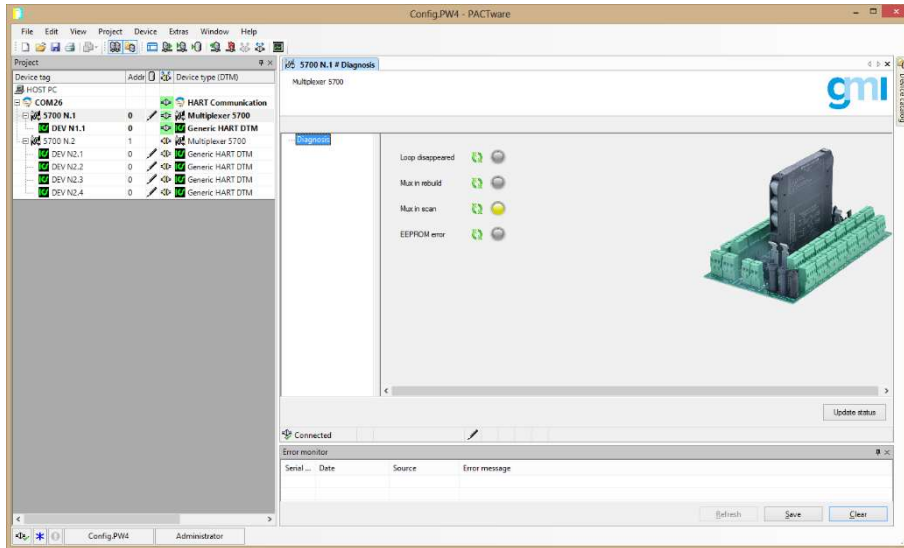
Software Revision\*: firmware release

Hardware Revision\*: hardware release

Default Preambles to Devices: default number of preambles sent to the field devices. This default value will be adapted channel by channel after rebuilding.

### 17.1.5 HART® Mux 5700 Diagnosis Windows

To enter the Diagnosis Window (Figure 8), right click on the HART® Mux 5700 in the Project Window and select Diagnosis from the context menu.



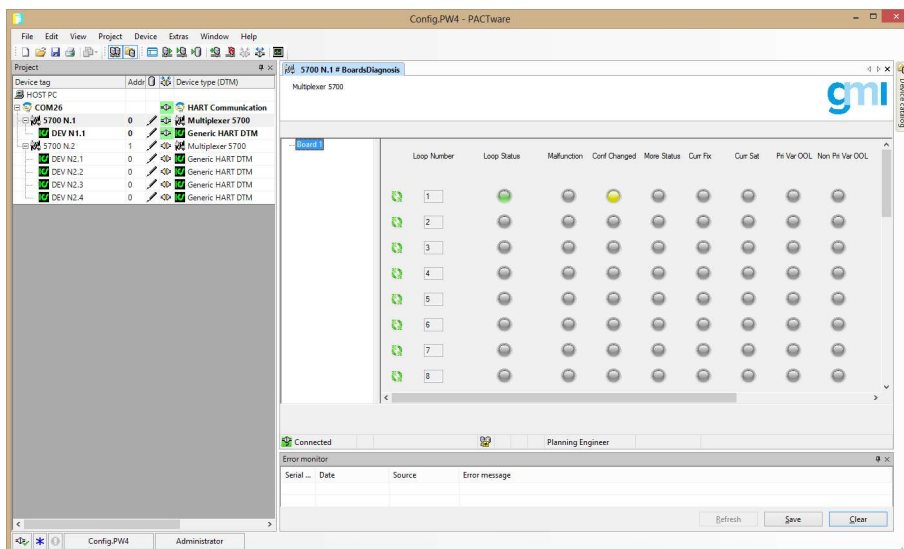
**Figure 8: HART® Mux 5700 Diagnosis Window**

When entering the Diagnosis Window, the DTM periodically communicates with the corresponding hardware to report the following information:

1. Loop disappeared: at least one loop has disappeared.
2. Mux in rebuild: the HART® Mux 5700 is busy in rebuilding.
3. Mux in scan: the HART® Mux 5700 is scanning over the active channels.
4. EEPROM error: the built-in non-volatile memory has an unrecoverable failure.

### 17.1.6 HART® Mux 5700 Boards Diagnosis Windows

To enter the Boards Diagnosis Window (Figure 9), right click on the HART® Mux 5700 in the Project Window and select Additional Functions -> BoardsDiagnosis from the context menu.



**Figure 9: HART® Mux 5700 Boards Diagnosis Window**

*Note: cumulative screens (BoardsDiagnosis and Display Values) are highly resource consuming for the operating system. Opening one window of each kind at a time is suggested.*

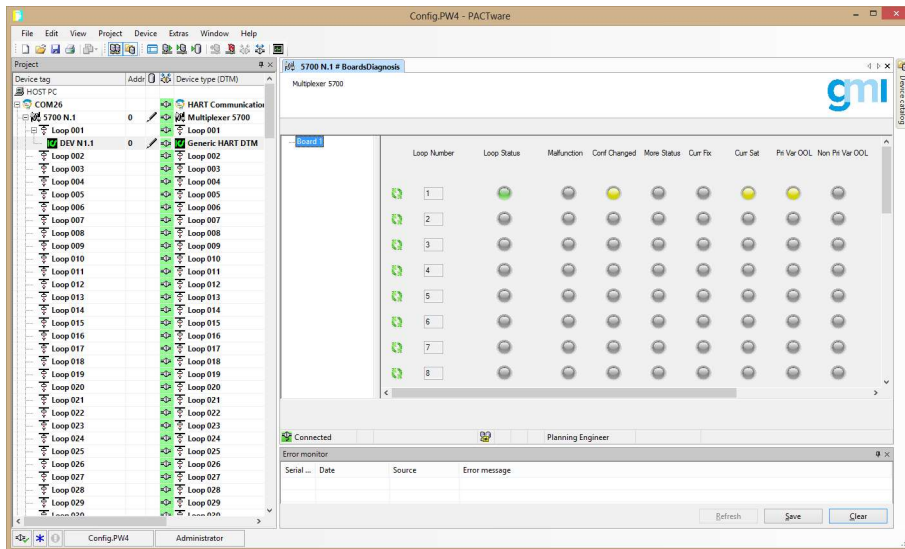
On the left the connected termination boards are listed. By clicking on a single board all the information is given about the status of each device connected to it. Note that the data are periodically updated.

For each loop the following data are displayed:

- Loop status: grey means loop not active, green means loop active, red means loop disappeared.
- Malfunction: red means device malfunction.

- Conf Changed: yellow means that the device configuration has changed since the last configuration save.
- More Status: yellow means that more status information is available for the device.
- Curr Fix: yellow means that the current is in fixed mode.
- Curr Sat: yellow means that the current is saturated.
- Pri Var OOL: yellow means that the primary variable is out of limits.
- Non Pri Var OOL: yellow means that a non-primary variable is out of limits.

In case of anomalies on a loop, it is possible to retrieve the specific transmitter from the loop number by right clicking on the HART® Mux 5700 in the Project Window and selecting *Display Channels* (Figure 10):

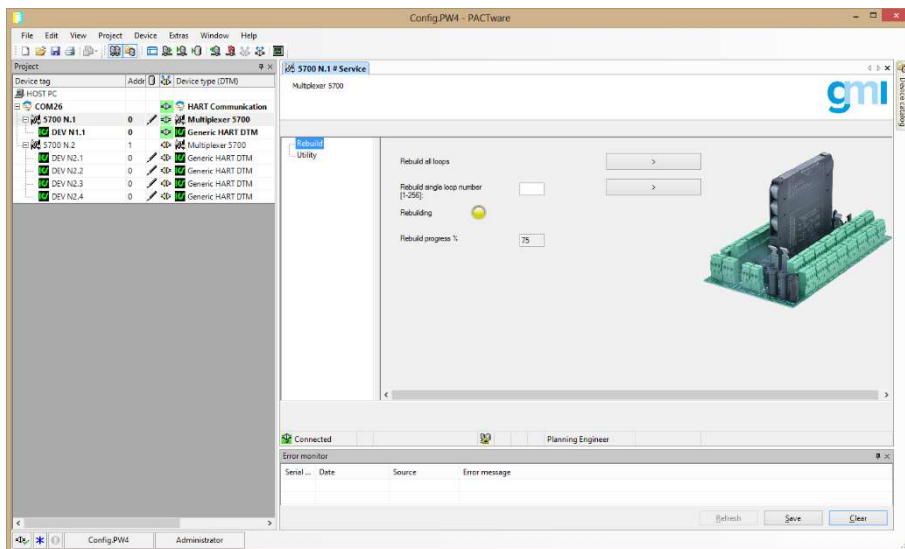


**Figure 10: Display Channel on Project Window**

### 17.1.7 HART® Mux 5700 Service Windows

To enter the Service Window, right click on the HART® Mux 5700 in the Project Window and select *Additional Functions -> Service*.

Two sections are available in this window, *Rebuild* (Figure 11) and *Utility* (Figure 13).



**Figure 11: HART® Mux 5700 Service Rebuild Window**

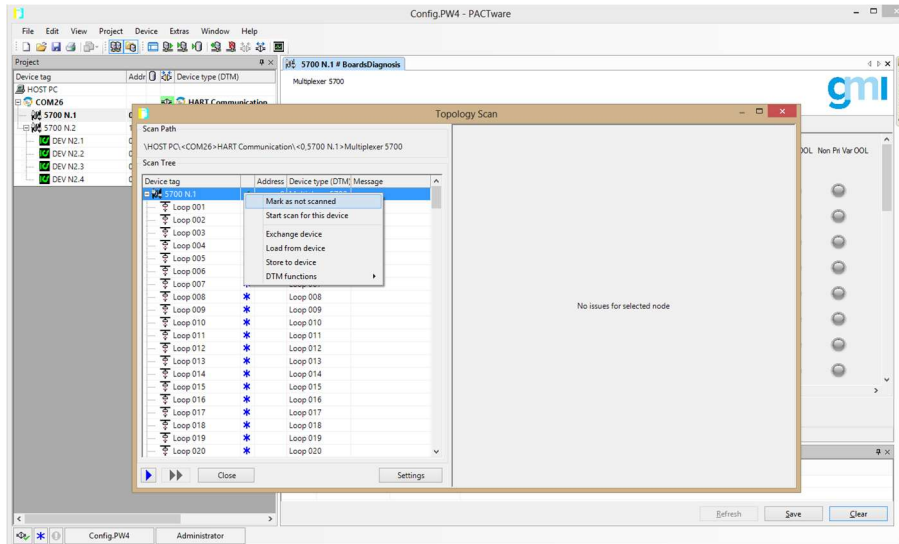
At start-up all loops are rebuilt, i.e. the HART® Mux 5700 browses all channels searching for connected devices and it stores the identity information for each field slave. However, at any point the user can ask the mux to perform the build operation again, on all or on a single loop.

The HART® Mux 5700 makes available the following services:

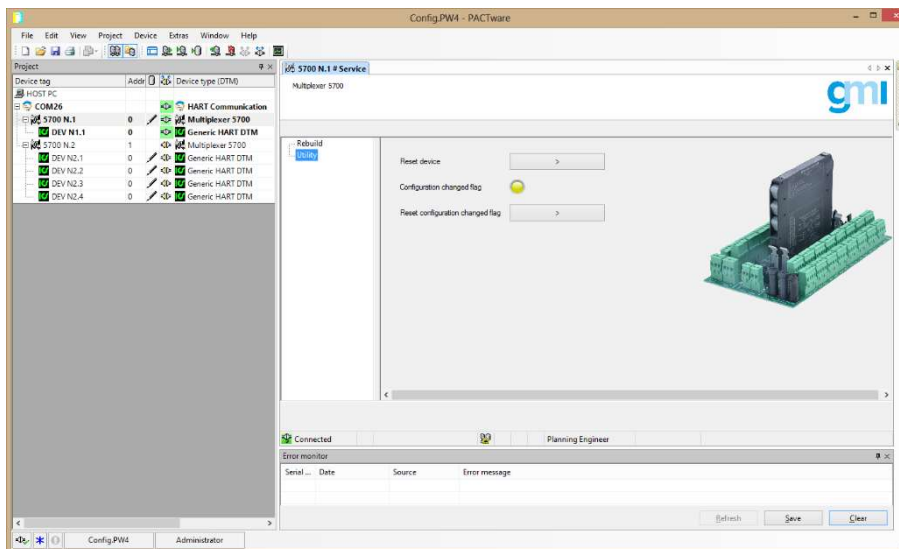
- Rebuild loops: all loops are rebuilt.
- Rebuild single loop number: a single loop in the range 1 to 256 can be rebuilt.

The yellow light indicates that the HART® Mux 5700 is rebuilding.

After any rebuild operation it is recommended to restart the Topology Scan on the specific multiplexer. To do so, right click on the HART® Mux 5700 in the Project Window and select Topology Scan. On the upcoming window, right click on the root multiplexer, select *Mark as not scanned* and run the search. The devices below the multiplexer are visited anew and the differences in the topology are found.



**Figure 12: Topology Scan on Mux level**

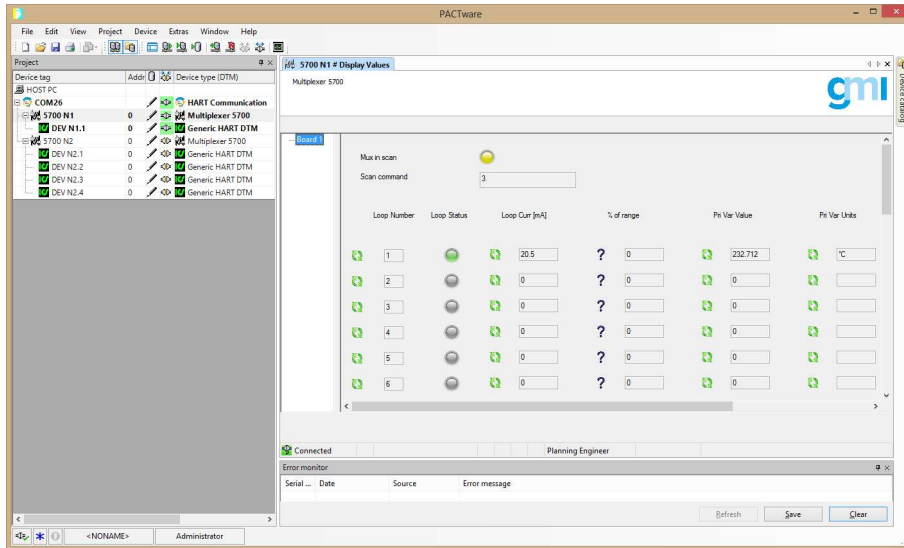


**Figure 13: HART® Mux 5700 Service Utility Window**

In the *Utility Window* the user can reset the device, monitor and reset the configuration changed flag.

### 17.1.8 HART® Mux 5700 Display Values Windows

To enter the Display Values Window (Figure 14), right click on the HART® Mux 5700 in the Project Window and select *Additional Functions -> Display Values* from the context menu.



**Figure 14: HART® Mux 5700 Display Values Window**

In this window the loop current, the percent of range, the primary variable value and the primary variable unit of the connected devices are displayed. Note that this window requires that the HART® Mux 5700 is in scan mode. Depending on the specific scan command, a different subset of variables is available:

1. Command 1: primary variable value and unit.
2. Command 2: primary variable loop current and percent of range.
3. Command 3: primary variable loop current, primary variable value and unit.

*Note: cumulative screens (BoardsDiagnosis and Display Values) are highly resource consuming for the operating system. Opening one window of each kind at a time is suggested.*

### 17.1.9 HART® Mux 5700 Device Specific Status

The Device-Specific Status contains status information of the HART® Mux 5700 that can be accessed through the HART® Command 48 (Read Additional Device Status). The following table indicates how the data are organized:

Byte Number	Bit Position	Description
0	0	Eeprom error
	1	Rebuild in progress
	2	Scan in progress
	3	Loop disappeared
1-2		Loop number in rebuild
3-4		Total number of supported loops

**Table 2: Device-Specific Status**

### 17.1.10 HART® Mux 5700 Device-Specific Commands Specification

The HART® Mux 5700 supports the following HART® device-specific commands.

#### Supported Device Specific Commands

Code	Description
128	Read Multiplexer Topology
129	Read Device Long Address
130	Read Master type
131	Write Master Type
132	Read Loop Search Type
133	Write Loop Search Type
134	Read Retries Number

135	Write Retries Number
136	Rebuild Single Loop
137	Rebuild All Loops
138	Read Scan Status
139	Write Scan Status
140	Read Scan Command
141	Write Scan Command
142	Read Loop Scan Status
143	Write Loop Scan Status
144	Write Protection Switch
145	Read Cumulative Loop/Device Status
146	Read Cumulative Dynamic Data
150	Read Configuration-Changed Flag

The enumerative types referenced in the commands are defined in the following:

### Master Type

Code	Description
0	Secondary Master
1	Primary Master

### Loop Search Type

Code	Description
0	Polling Address 0
1	Polling Address 0 to 15

### Scan Status

Code	Description
0	Scan Disabled
1	Scan Enabled

### Scan HART® Command

Code	Description
0	Scan HART® Command 1
1	Scan HART® Command 2
2	Scan HART® Command 3

### Loop Scan Status

Code	Description
0	Loop Scan Enabled
1	Loop Scan Disabled

### Write Protection Status

Code	Description
0	Write Protection Disabled
1	Write Protection Enabled

### Loop Status

Code	Description
0	No Device
1	Active Device
2	Device Disappeared

## Configuration-Changed Flag

Code	Description
0	Configuration Not Changed
1	Configuration Changed

### 17.1.10.1 Command 128 Read Multiplexer Topology

This command allows the master to request the total number of available loops and termination boards connected to the HART® Mux 5700, and the distribution of the loops among the different boards.

Up to 8 termination boards can be connected to a single HART® Mux 5700. The response length depends on the actual number of boards: for example, in case of two boards, the response is 8-byte long.

#### Request Data Bytes

Byte	Format	Description
None		

#### Response Data Bytes

Byte	Format	Description
0-1	Unsigned-16	Total number of available loops
2-3	Unsigned-16	Total number of termination boards
4-5	Unsigned-16	Number of loop on the 1st board
6-7	Unsigned-16	Number of loop on the 2nd board
8-9	Unsigned-16	Number of loop on the 3rd board
10-11	Unsigned-16	Number of loop on the 4th board
12-13	Unsigned-16	Number of loop on the 5th board
14-15	Unsigned-16	Number of loop on the 6th board
16-17	Unsigned-16	Number of loop on the 7th board
18-19	Unsigned-16	Number of loop on the 8th board

#### Command-Specific Response Codes

Code	Class	Description
0	Success	No command-specific errors
1-127		Undefined

### 17.1.10.2 Command 129 Read Device Long Address

This command allows the master to request the long address of the device connected to a given loop.

#### Request Data Bytes

Byte	Format	Description
0	Unsigned-8	Loop Number (0...255)

#### Response Data Bytes (loop not supported or no device)

Byte	Format	Description
0-1	Unsigned-16	"0"

#### Response Data Bytes (supported loop and device active)

Byte	Format	Description
0	Unsigned-8	Loop Number (0...255)
1-3	Unsigned-24	Reserved
4-5	Enum	Expanded Device Type (see Common Table 1)
6-8	Unsigned-24	Unique Device ID
9-10	Unsigned-16	Reserved

### Command-Specific Response Codes

Code	Class	Description
0	Success	No command-specific errors
1-4		Undefined
5	Error	Too Few Bytes Received
6-127		Undefined

#### 17.1.10.3 Command 130 Read Master Type

This command allows the master to request the HART® Mux 5700 field master type.

#### Request Data Bytes

Byte	Format	Description
None		

#### Response Data Bytes

Byte	Format	Description
0	Enum	Master Type (see Master Type Table)

### Command-Specific Response Codes

Code	Class	Description
0	Success	No command-specific errors
1-127		Undefined

#### 17.1.10.4 Command 131 Write Master Type

This command allows the master to write the HART® Mux 5700 field master type.

#### Request Data Bytes

Byte	Format	Description
0	Enum	Master Type (see Master Type Table)

#### Response Data Bytes

Byte	Format	Description
0	Enum	Master Type (see Master Type Table)

### Command-Specific Response Codes

Code	Class	Description
0	Success	No command-specific errors
1		Undefined
2	Error	Invalid Selection
3-4		Undefined
5	Error	Too Few Bytes Received
6		Undefined
7	Error	In Write Protect Mode
8-31		Undefined
32	Error	Busy
33-127		Undefined

#### 17.1.10.5 Command 132 Read Loop Search Type

This command allows the master to request the loop search type used during building.

#### Request Data Bytes

Byte	Format	Description
None		

### Response Data Bytes

Byte	Format	Description
0	Enum	Loop Search Type (see Loop Search Type Table)

### Command-Specific Response Codes

Code	Class	Description
0	Success	No command-specific errors
1-127		Undefined

#### 17.1.10.6 Command 133 Write Loop Search Type

This command allows the master to write the loop search type used during building.

### Request Data Bytes

Byte	Format	Description
0	Enum	Loop Search Type (see Loop Search Type Table)

### Response Data Bytes

Byte	Format	Description
0	Enum	Loop Search Type (see Loop Search Type Table)

### Command-Specific Response Codes

Code	Class	Description
0	Success	No command-specific errors
1		Undefined
2	Error	Invalid Selection
3-4		Undefined
5	Error	Too Few Bytes Received
6		Undefined
7	Error	In Write Protect Mode
8-31		Undefined
32	Error	Busy
33-127		Undefined

#### 17.1.10.7 Command 134 Read Retries Number

This command allows the master to request the number of retries configured in the HART® Mux 5700 field master both in case of device busy and in case of communication errors.

### Request Data Bytes

Byte	Format	Description
None		

### Response Data Bytes

Byte	Format	Description
0	Unsigned-8	Retries Number on Busy
1	Unsigned-8	Retries Number on Error

### Command-Specific Response Codes

Code	Class	Description
0	Success	No command-specific errors
1-127		Undefined

#### 17.1.10.8 Command 135 Write Retries Number

This command allows the master to configure the number of retries in the HART® Mux 5700 field master both in case of device busy and in case of communication errors.

### Request Data Bytes

Byte	Format	Description
0	Unsigned-8	Retries Number on Busy
1	Unsigned-8	Retries Number on Error

### Response Data Bytes

Byte	Format	Description
0	Unsigned-8	Retries Number on Busy
1	Unsigned-8	Retries Number on Error

### Command-Specific Response Codes

Code	Class	Description
0	Success	No command-specific errors
1-4		Undefined
5	Error	Too Few Bytes Received
6		Undefined
7	Error	In Write Protect Mode
8-31		Undefined
32	Error	Busy
33-127		Undefined

#### 17.1.10.9 Command 136 Rebuild Single Loop

This command allows the master to force the rebuild of a single loop.

### Request Data Bytes

Byte	Format	Description
0	Unsigned-8	Loop Number (0...255)

### Response Data Bytes

Byte	Format	Description
None		

### Command-Specific Response Codes

Code	Class	Description
0	Success	No command-specific errors
1-4		Undefined
5	Error	Too Few Bytes Received
6-127		Undefined

#### 17.1.10.10 Command 137 Rebuild All Loops

This command allows the master to force the rebuild of all loops.

### Request Data Bytes

Byte	Format	Description
None		

### Response Data Bytes

Byte	Format	Description
None		

### Command-Specific Response Codes

Code	Class	Description
0	Success	No command-specific errors
1-127		Undefined

### 17.1.10.11 Command 138 Read Scan Status

This command allows the master to request the HART® Mux 5700 scan status.

#### Request Data Bytes

Byte	Format	Description
None		

#### Response Data Bytes

Byte	Format	Description
0	Enum	Scan Status (see Scan Status Table)

#### Command-Specific Response Codes

Code	Class	Description
0	Success	No command-specific errors
1-127		Undefined

### 17.1.10.12 Command 139 Write Scan Status

This command allows the master to write the HART® Mux 5700 scan status.

#### Request Data Bytes

Byte	Format	Description
0	Enum	Scan Status (see Scan Status Table)

#### Response Data Bytes

Byte	Format	Description
0	Enum	Scan Status (see Scan Status Table)

#### Command-Specific Response Codes

Code	Class	Description
0	Success	No command-specific errors
1		Undefined
2	Error	Invalid Selection
3-4		Undefined
5	Error	Too Few Bytes Received
6		Undefined
7	Error	In Write Protect Mode
8-31		Undefined
32	Error	Busy
33-127		Undefined

### 17.1.10.13 Command 140 Read Scan Command

This command allows the master to request the HART® Mux 5700 scan HART® command.

#### Request Data Bytes

Byte	Format	Description
None		

#### Response Data Bytes

Byte	Format	Description
0	Enum	Scan Command (see Scan HART® Command Table)

#### Command-Specific Response Codes

Code	Class	Description
0	Success	No command-specific errors

1-127 Undefined

#### 17.1.10.14 Command 141 Write Scan Command

This command allows the master to write the HART® Mux 5700 scan HART® command.

##### Request Data Bytes

Byte	Format	Description
0	Enum	Scan Command (see Scan HART® Command Table)

##### Response Data Bytes

Byte	Format	Description
0	Enum	Scan Command (see Scan HART® Command Table)

##### Command-Specific Response Codes

Code	Class	Description
0	Success	No command-specific errors
1		Undefined
2	Error	Invalid Selection
3-4		Undefined
5	Error	Too Few Bytes Received
6		Undefined
7	Error	In Write Protect Mode
8-31		Undefined
32	Error	Busy
33-127		Undefined

#### 17.1.10.15 Command 142 Read Loop Scan Status

This command allows the master to request the single loop scan status.

##### Request Data Bytes

Byte	Format	Description
0	Unsigned-8	Loop Number (0...255)

##### Response Data Bytes

Byte	Format	Description
0	Unsigned-8	Loop Number (0...255)
1	Enum	Loop Scan Status (see Loop Scan Status Table)

##### Command-Specific Response Codes

Code	Class	Description
0	Success	No command-specific errors
1		Undefined
2	Error	Invalid Selection
3-4		Undefined
5	Error	Too Few Bytes Received
6-127		Undefined

#### 17.1.10.16 Command 143 Write Loop Scan Status

This command allows the master to (de-)activate the single loop scan.

##### Request Data Bytes

Byte	Format	Description
0	Unsigned-8	Loop Number (0...255)
1	Enum	Loop Scan Status (see Loop Scan Status Table)

### Response Data Bytes

Byte	Format	Description
0	Unsigned-8	Loop Number (0...255)
1	Enum	Loop Scan Status (see Loop Scan Status Table)

### Command-Specific Response Codes

Code	Class	Description
0	Success	No command-specific errors
1		Undefined
2	Error	Invalid Selection
3-4		Undefined
5	Error	Too Few Bytes Received
6		Undefined
7	Error	In Write Protect Mode
8-31		Undefined
32	Error	Busy
33-127		Undefined

#### 17.1.10.17 Command 144 Write Protection Switch

This command allows the master to (de-)activate the module write protection.

### Request Data Bytes

Byte	Format	Description
0	Enum	Write Protection Status (see Write Protection Status Table)

### Response Data Bytes

Byte	Format	Description
0	Enum	Write Protection Status (see Write Protection Status Table)

### Command-Specific Response Codes

Code	Class	Description
0	Success	No command-specific errors
1		Undefined
2	Error	Invalid Selection
3-4		Undefined
5	Error	Too Few Bytes Received
6-31		Undefined
32	Error	Busy
33-127		Undefined

#### 17.1.10.18 Command 145 Read Cumulative Loop/Device Status

This command allows the master to request the loop status and the device status of a bunch of channels.

The response length depends on the required number of loops: for example, in case of two loops, the response is 6-byte long. If the required loop is above the maximum number of supported channels, the corresponding loops status and device status are zero.

### Request Data Bytes

Byte	Format	Description
0	Unsigned-8	Start Loop Number (0...255)
1	Unsigned-8	Number of Loops

### Response Data Bytes

Byte	Format	Description
0	Unsigned-8	Start Loop Number (0...255)
1	Unsigned-8	Number of Loops
2	Enum	Start Loop Status (see Loop Status Table)
3	Unsigned-8	Start Device Status
4	Enum	Start+1 Loop Status
5	Unsigned-8	Start+1 Device Status
6	Enum	Start+2 Loop Status
7	Unsigned-8	Start+2 Device Status
8	...	...

### Command-Specific Response Codes

Code	Class	Description
0	Success	No command-specific errors
1-4		Undefined
5	Error	Too Few Bytes Received
6-127		Undefined

#### 17.1.10.19 Command 146 Read Cumulative Dynamic Data

This command allows the master to request the dynamic data of a bunch of channels. The white lines in the Response Data Table represent a unique header, while the blue lines are repeated for all required loops. As a consequence, the response length depends on the required number of loops: for example, in case of one loop the response is 35-byte long, in case of two loops, the response is 63-byte long, in case of 3 loops the response is 91-byte long and so on.

### Request Data Bytes

Byte	Format	Description
0	Unsigned-8	Start Loop Number (0...255)
1	Unsigned-8	Number of Loops

### Response Data Bytes

Byte	Format	Description
0	Unsigned-8	Start Loop Number (0...255)
1	Unsigned-8	Number of Loops
2-3	Enum	Scan Status (see Scan Status Table)
4-5	Enum	Scan Command (see Scan HART® Command Table)
6	Enum	Start Loop Status (see Loop Status Table)
7-10	Float	Primary Variable Loop Current [mA]
11-14	Float	Primary Variable Percent of Range [%]
15	Enum	Primary Variable Unit Code (see Common Table 2)
16-19	Float	Primary Variable Value
20	Enum	Secondary Variable Unit Code (see Common Table 2)
21-24	Float	Secondary Variable Value
25	Enum	Tertiary Variable Unit Code (see Common Table 2)
26-29	Float	Tertiary Variable Value
30	Enum	Quaternary Variable Unit Code (see Common Table 2)
31-34	Float	Quaternary Variable Value

### Command-Specific Response Codes

Code	Class	Description
0	Success	No command-specific errors

1		Undefined
2	Error	Invalid Selection
3-4		Undefined
5	Error	Too Few Bytes Received
6-127		Undefined

#### 17.1.10.20 Command 150 Read Configuration-Changed Flag

This command allows the master to request the configuration-changed flag.

##### Request Data Bytes

Byte	Format	Description
None		

##### Response Data Bytes

Byte	Format	Description
0	Enum	Configuration-Changed Flag (see Configuration-Changed Flag Table)

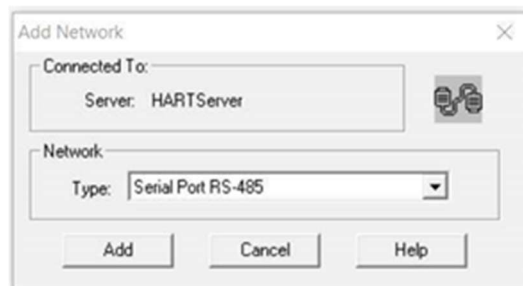
##### Command-Specific Response Codes

Code	Class	Description
0	Success	No command-specific errors
1-127		Undefined

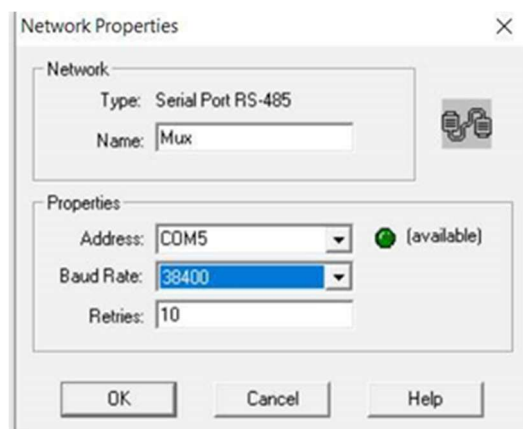
## 17.2 HART® OPC Server

The HART® Mux 5700 communicates to the OPC (Open Platform Communications) Server through the I/O Systems Commands belonging to the Common Practice section of the HART® protocol.

To start the communication, the network should properly be set up together with its properties. Right click on HARTServer and configure the communication parameters.

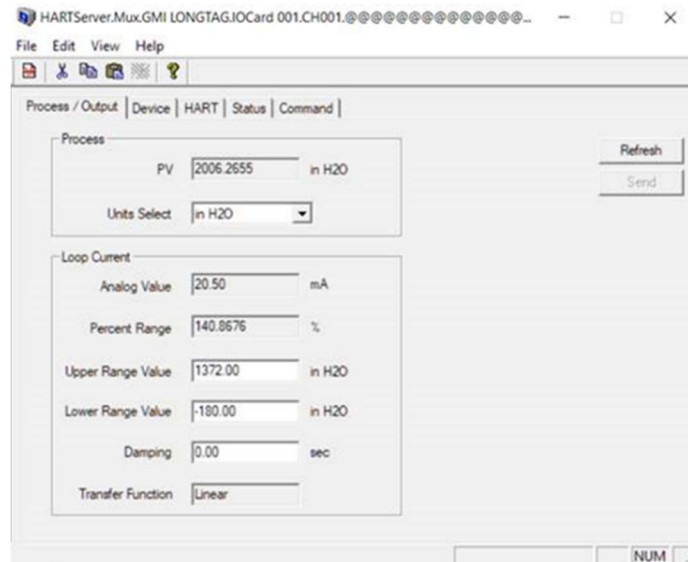


**Figure 15: HART® OPC Server Add Network window**



**Figure 16: HART® OPC Server Network Properties window**

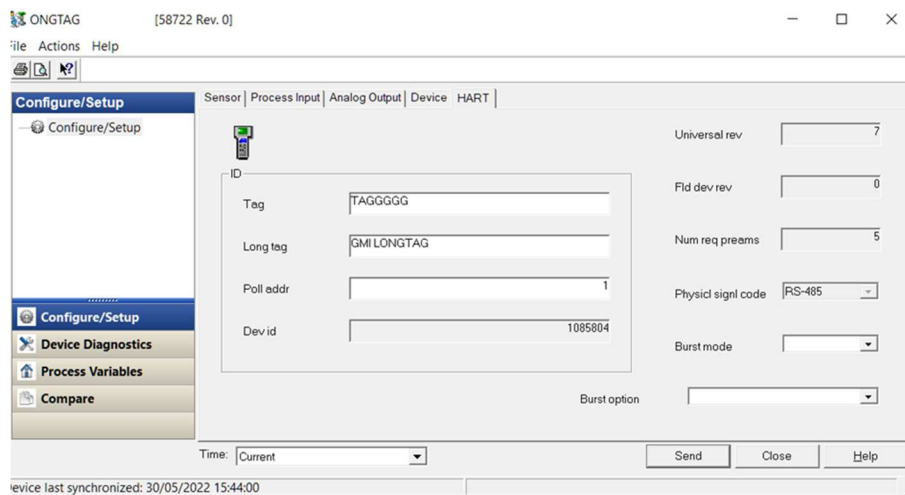




**Figure 20: Specific device characteristics**

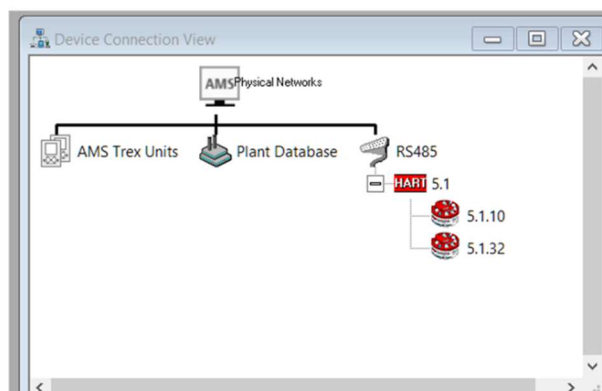
### 17.3 AMS Device Manager™ / ARCOM Protocol

After having configured the HART® Mux 5700-110 through the SWC5090 Software (please refer to the corresponding section), the HART® Mux 5700-110 communicates to the AMS Device Manager™ through the ARCOM protocol. It will be identified as a standard HART® multiplexer, with the possibility of changing a few universal parameters: tag, long tag, descriptor, message and polling address.

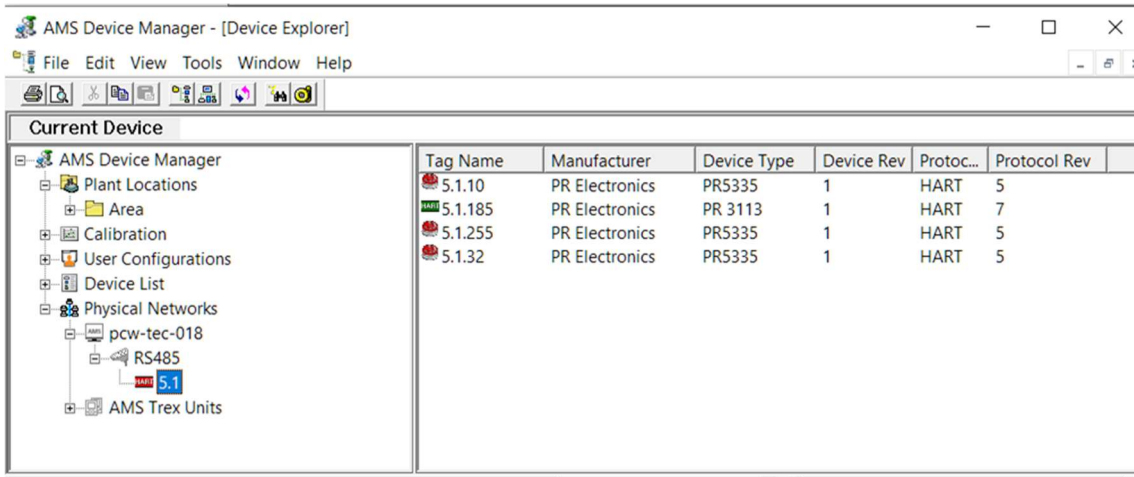


**Figure 21: AMS Device Manager™ configuration window**

By exploring the network connected to the Multiplexer, all field devices are found and they can be entered individually.



**Figure 22: AMS Device Manager™ Device Connection View**



**Figure 23: AMS Device Manager™ Device Explorer View**